

ITEM #	Part Number	Description	QTY.
1	WHLA7BASE(A)	BASE, A7 1.75 Bolt Pattern	1
2	MSCAN4-15A	BOLT, HEX	1
3	MSC.25-28CLOCK	NUT, CLOCK	1
4	WHLA7EXT-1	AXLE, 0.75 THREADED	1
5	WHLA7SL	SLEEVE, A7 AXLE	1
6	MSCNL5	WASHER SET, NORLOC	4
7	MSC10-24X.62TBHCS	SCREW, T-25IP TORX BHCS	4
8	MSCAN960-1216	WASHER, AN960	1
9	MSC.11x1.5COTTERPI	PIN, COTTER ZINC	1
10	MSC.75-16HEXNUT/SL		1

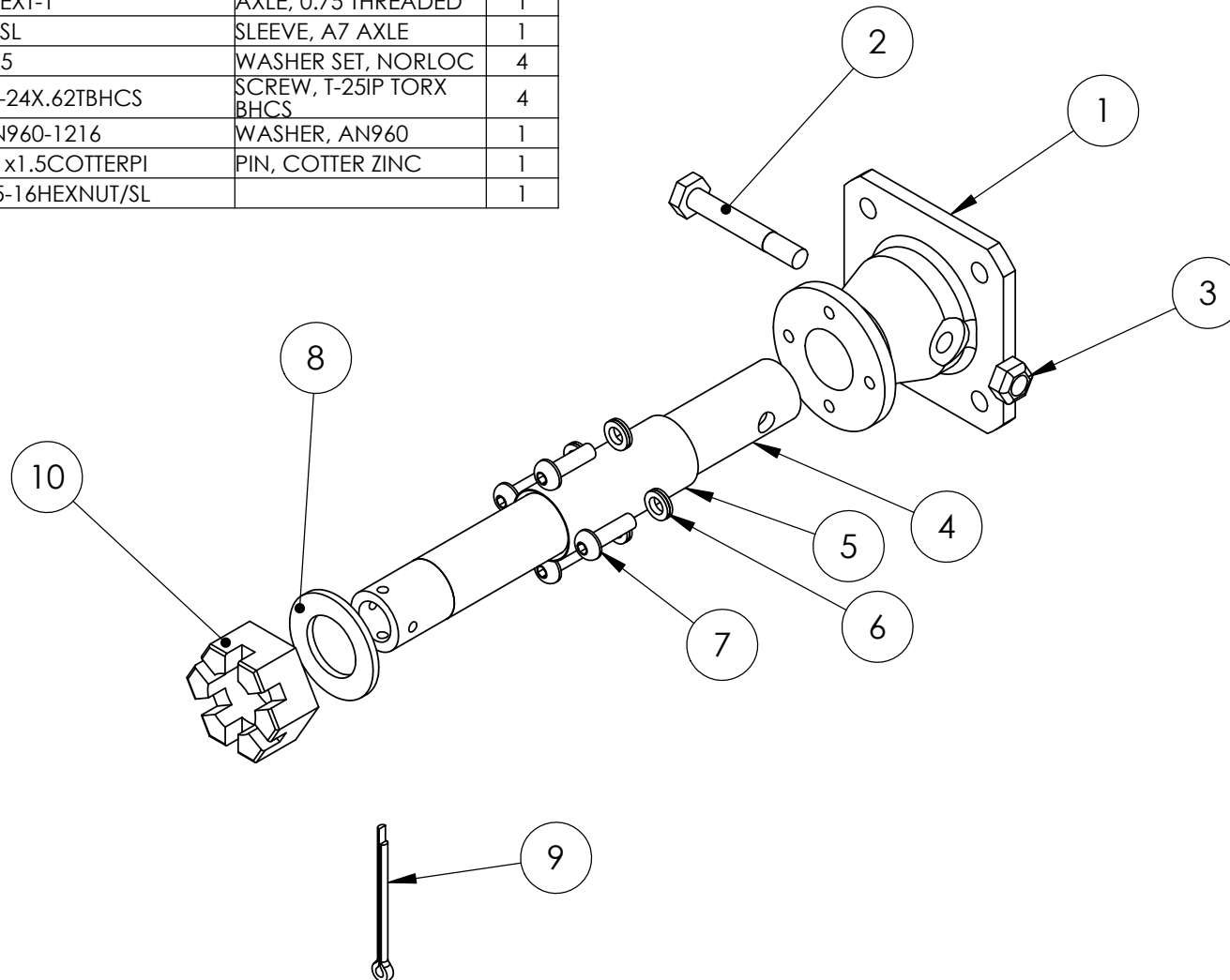

**MATCO mfg**

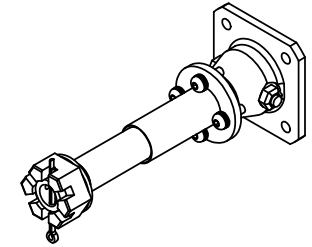

2361 S 1560 West  
Woods Cross, UT 84087 USA

NOMENCLATURE  
AXLE, ASSY AXLE7

PART NUMBER  
WHLAXLE7

SCALE  
1:2

TOLERANCES  
(EXCEPT AS NOTED)  
DO NOT SCALE DRAWING  
LINEAR .XX = + .03  
.XXX = + .01  
ANGULAR ± 1/2  
CONCENTRIC ± .01

MATERIAL  
VARIES

DRAWING NO.  
AXLE/AXLE7

REVISION  
A

Est Wt. (lb)  
1.38

DRAWN BY  
George R. Happ

FINISH  
VARIES

DATE  
9/22/2023

CHECKED BY

SHEET 1 OF 1  
SHEET SIZE A