

STEP 1: Without O-ring installed, insert intensifier sleeve into housing until firmly seated to determine length "x". Length "x" is determined by measuring the distance between the end of the intensifier sleeve and the end of the housing.

NOTE For model MC5-A sleeve may bottom on pedestal.

STEP 2: Remove "x" + .325 inches of material from the *bottom* end of the intensifier sleeve. Insert the sleeve into the housing *without* o-ring installed to test your length. Sleeve should be greater than 0.06 away from snap ring bottom (shown in step3). Remove additional material if required.

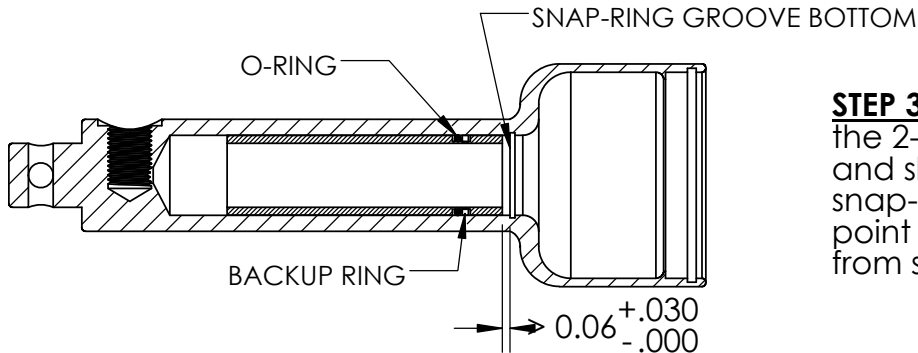
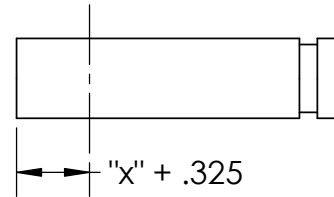

STEP 3: After vigorously lubricating the snap ring groove, install the 2-014 o-ring and MSC8-014ST backup ring onto the sleeve and slowly re-insert into housing until the o-ring reaches the snap-ring groove. Sharply rap the sleeve to move it past this point and continue until top of sleeve is greater than .060 away from snap ring bottom.

STEP 4: Remove the old piston and install the new .500 OD piston with the 2-109 o-ring. Slide the shaft and piston assembly into the housing compressing the spring. Then, insert the W.625L retainer washer and new 1308-.625 snap ring.

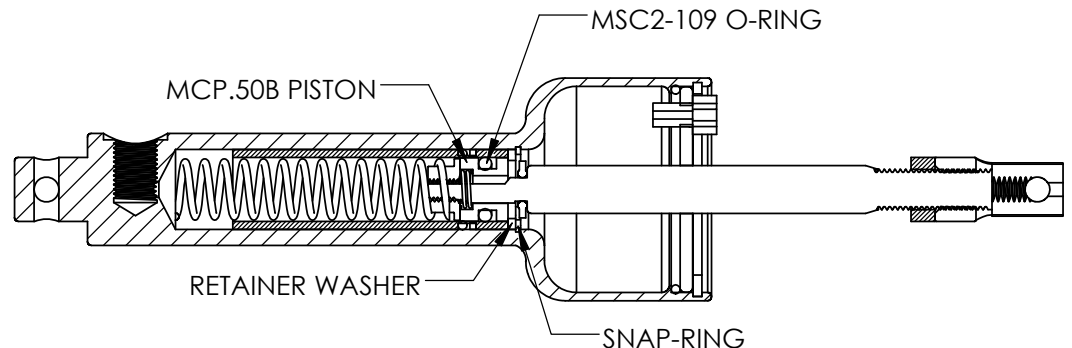

MATCO mfg



2361 S. 1560 West
Woods Cross, Utah 84087 USA

NOMENCLATURE
MC-5 WITH INTENSIFIER

MATERIAL
VARIES

PART NUMBER
MC-5-INTENSIFIER-INSTRUCTIONAL

DRAWING NO.
MASTER/MC-5i-INSTRUCTIONAL

SCALE
2:3

REVISION
NC Est Wt. (lb)
0.11

TOLERANCES
(EXCEPT AS NOTED)
DO NOT SCALE DRAWING
LINEAR .XX = + .03
.XXX = + .01
ANGULAR ± 1/2
CONCENTRIC ± .01

DRAWN BY
Sally Christensen

FINISH
VARIES

DATE
9/28/2021

CHECKED BY

SHEET 1 OF 1
SHEET SIZE A