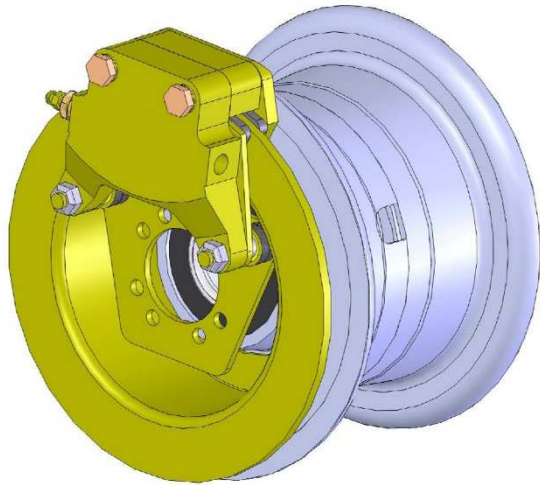

TABLE OF CONTENTS

MATCO mfg

Wheels & Brakes



WE51 / WE51L

WE51L.75

External Caliper

5" E - Series

Wheel and Brake

Technical Service Bulletin

SUBJECTS

PAGE

A.	WE51 Wheel & Brake Assembly	3
B.	WE51 Parts List	5
C.	WE51L Parts List	6
D.	WE51L.75 Parts List	7
E.	Assembly Diagram	8
F.	Braking Lining Wear Limits	10
G.	Brake Disc Inspection	11
H.	Brake Lining Installation	12
I.	Mounting the Tire & Tube	13
J.	WE51 / WE51L Wheel Assembly Instructions	15
K.	Wheel Assembly Torque Values	17
L.	Caliper Alignment	17
M.	Bleeding the Brake System	18
N.	Conditioning Procedures	21
O.	Maximizing Brake Output	22
P.	Lubricants	29
Q.	Technical Assistance	30

DRAWINGS

PAGE

E-1	Wheel & Brake Assembly Drawing	8
E-2	Caliper Housing Configurations	9
F-1	Brake Lining Wear Limits	10
G-1	Minimum Disc Wear	12
I-1	Tire Mounting Drawing	13
I-2	Tire Mounting Photo	14
L-1	Caliper Alignments	17
M-1	Pressure Bleeding Brake Schematic	19
M-2	Vacuum Bleeding Brake Schematic	20
O-1	Pedal Geometry	26
O-2	Pedal Geometry	26
O-3	Pedal Geometry	27
O-4	Pivot Connect Geometry	27
O-5	Heel Brake Geometry	28

A. WE51 'E' SERIES FIVE-INCH WHEEL

DIMENSIONS

The WE51 / WE51L / WE51L.75 wheels are an 'E' series FIVE inch wheel and utilize an external caliper for easy maintenance.

The WE51 has a width of 5.01'' while the WE51L & WE51L.75 have a width of 4.95 inches. The caliper spacing is 1.1 inches on all three models.

Bearing spacing is 3.03 inches on the WE51 and 2.83 inches on the WE51L & WE51L.75. Axle spacing for the WE51 is 1.10 inches, and 1.39 inches for the WE51L and WE51L.75. The weight on the WE51 is 6.9 lbs, and includes the wheel, brake assembly, bearings and brake plate. Weight on the WE51L & WE51L.75 is 6.6 lbs. The bearing axle diameters are 1.25 inches for the WE51 & WE51L, and .75 inches for the WE51L.75.

FEATURES

The WE51 series is cast from 535.2 aluminum alloy. It is used for its superior strength, light weight, and resistance to corrosion that is inherently found in aluminum wheels. The WE51 uses a 1.25 or .75 inch tapered roller bearing, designed and tested for long life and resistance to bearing fatigue. The "E" series wheel features a single piston brake assembly with an external caliper for easy maintenance. Caliper removal is accomplished by removing two bolts giving easy access to the linings. Al-Ni-Brz bushings are used on 'E' series wheels to ensure smooth caliper travel. Machining of the wheel offers precision cuts, and smooth clean surfaces for use with a variety of commercial tires. The WE51 is fitted with the A1B bolt on axle, the WE51L with the A1A. A1 axles are made of black anodized 2024-T351 alloys with a bolt-hole diameter of 1.9 inches.

COMPATABILITY

The WE51 can be mounted on the same axle as the Cleveland 199-102 K, by leaving the ¼ inch spacers on the axle. (No spacers are required when using the MATCO mfg Axle.)

TIRE & TUBE

Precision machining on the WE51 series wheel allows for a variety of tires to include the Goodyear, McCreary, and Michelin. Any 5.00-5 tire / tube combination can be used.

PERFORMANCE

The WE51 is designed for the following performance standards:

Static Capacity	1,420 pound Load
Load Limit	4,260 pounds
Max Accelerate/Stop (Kinetic Energy)	118,121 foot-pounds
Torque Rating	2,085 in-lbs at 450psi

The WE51L is designed for the following performance standards:

Static Capacity	1,200 pound Load
Load Limit	3,600 pounds
Max Accelerate/Stop (Kinetic Energy)	118,121 foot-pounds
Torque Rating	2,085 in-lbs at 450psi

The WE51L.75 is designed for the following performance standards:

Static Capacity	1,185 pound Load
Load Limit	3555 pounds
Max Accelerate/Stop (Kinetic Energy)	118,121 foot-pounds
Torque Rating	2,085 in-lbs at 450psi

B. WE51 PARTS LIST / WHLBE5-1

DWG #	PART #	QTY	DESCRIPTION
1	MSCAN4-16A	2	HEX HEAD BOLT
2	MSC4-4	2	BRASS RIVET
3	MSCAN960-416	6	WASHER
3A	MSCNL1/4	2	NORDLOCK WASHER
4	WHLBSBE5	1	STATIONARY BRAKE
5	WHLM66-106	2	LINING
6	MSC4-6	2	BRASS RIVET
7	WHLBP AE1.38	1	BRAKE PLATE 1.38
8	WHLBSPE5	4	SPACER 5/6"
9	WHLMBSE5	1	MOVABLE BRAKE SHOE
10	SEE DRAWING E-2	1	PISTON 5" BRAKE
11	MSC2-222	1	O-RING, BUNA N
12	SEE DRAWING E-2	1	PUCK HOUSING 5/6"
13	MSCAN363-428	3	FLEX LOCK NUT
14	WHLLM6700SLS	2	1.25" TRB Single Lip Seal
15	WHLLM67010	2	1.25" BEARING, RACE
16	WHLWE51 / 1.25	1	WHEEL VALVE HALF,
17	WHLBE51 / 1.25	1	WHEEL BACK HALF
18	WHLD164-017	1	EXTERNAL BRAKE DISC
19	NOT REPLACEABLE	2	SEE #7
20	MSCAN4-23A	3	BOLT, HEX HEAD
21	MSC.234-X.50IL	1	DUST PLUG
22	MSCF6446-007	1	BRAKE BLEEDER VALVE
23	MSCBBS(A)	1	BRAKE BLEEDER SEAT
24	MSC.25-20CRLOCK	2	NYLOCK NUT
25	MSC2X	1	CAPLUG
26	MSC.25-20X1.75SHCS	2	SOCKET HEAD CAP
27	WHLBSP6	2	SPACER, DUAL / TRIPLE

C. WE51L PARTS LIST / WHLBE5-4

DWG #	PART #	QTY	DESCRIPTION
1	MSCAN4-16A	2	HEX HEAD BOLT
2	MSC4-4	2	BRASS RIVET
3	MSCAN960-416L	6	WASHER
3A	MSCNL1/4	2	NORDLOCK WASHER
4	WHLBSBE5	1	STATIONARY BRAKE SHOE
5	WHLM66-106	2	LINING
6	MSC4-6	2	BRASS RIVET
7	WHLBP AE1.38SE	1	BRAKE PLATE 1.38, 0.188
8	WHLBSPE5	4	SPACER 5/6"
9	WHLMBSE5	1	MOVABLE BRAKE SHOE
10	SEE DRAWING E-2	1	PISTON 5" BRAKE
11	MSC2-222	1	O-RING, BUNA N
12	SEE DRAWING E-2	1	PUCK HOUSING 5/6"
13	MSCAN363-428	3	FLEX LOCK NUT
14	WHLLM6700LA	2	1.25" TAPERED ROLLER
15	WHLLM67010	2	1.25" BEARING, RACE
16	WHLW51 / 1.25	1	WHEEL VALVE HALF,
17	WHLNW511.25B / 1.25	1	WHEEL BACK HALF
18	WHLD164-017	1	EXTERNAL BRAKE DISC 5"
19	INTEGRATED BUSHING	2	BUSHING
20	MSCAN4-23A	3	BOLT, HEX HEAD
21	MSC.234-X.50IL	1	DUST PLUG
22	MSCF6446-007	1	BRAKE BLEEDER VALVE
23	MSCBBS(A)	1	BRAKE BLEEDER SEAT
24	MSC.25-20CRLOCK	2	NYLOCK NUT
25	MSC2X	1	CAPLUG
26	MSC.25-20X1.75SHCS	2	SOCKET HEAD CAP SCRE
27	WHLBSP6	2	SPACER, DUAL / TRIPLE

D. WE51L.75 PARTS LIST / WHLBE5-8

DWG #	PART #	QTY	DESCRIPTION
1	MSCAN4-16A	2	BOLT
2	MSC4-4	2	BRASS RIVET
3A	MSCNL1/4	2	NORDLOCK WASHER
3	MSCAN960-416L	2	WASHER
4	WHLBSE5	1	STATIONARY BRAKE SHOE
5	WHLM66-106	2	LINING
6	MSC4-6	2	BRASS RIVET
7	WHLBPAE.75	1	BRAKE PLATE 1.13
8	WHLBSPE5	4	SPACER
9	WHLMBSE5	1	MOVABLE BRAKE SHOE
10	SEE DRAWING E-2	1	PISTON
11	MSC2-222	1	O-RING, BUNA N
12	SEE DRAWING E-2	1	PUCK HOUSING
13	MSCAN363-428	3	FLEX LOCK NUT .25-28
14	WHLLM11900LA	2	TAPERED ROLLER BEARING
15	WHLLM11910	2	BEARING, RACE
16	WHLW51/.75	1	WHEEL VALVE HALF,
17	WHLNW51B/.75	1	WHEEL BACK HALF
18	WHLD164-017	1	BRAKE DISC 5" BRAKE
19	INTEGRATED BUSHING	2	BUSHING
20	MSCAN4-23A	3	BOLT, HEX HEAD
21	MSC.234-X.50IL	1	DUST PLUG
22	MSCF6446-007	1	BRAKE BLEEDER VALVE
23	MSCBBS(A)	1	BRAKE BLEEDER SEAT
24	MSC.25-20CRLOCK	2	LOCK NUT
25	MSC2X	1	CAPLUG
26	MSC.25-20X1.75SHCS	2	BOLT, SHCS
27	WHLBSP6	2	SPACER

E. BRAKE ASSEMBLY DRAWING

Fig E-1

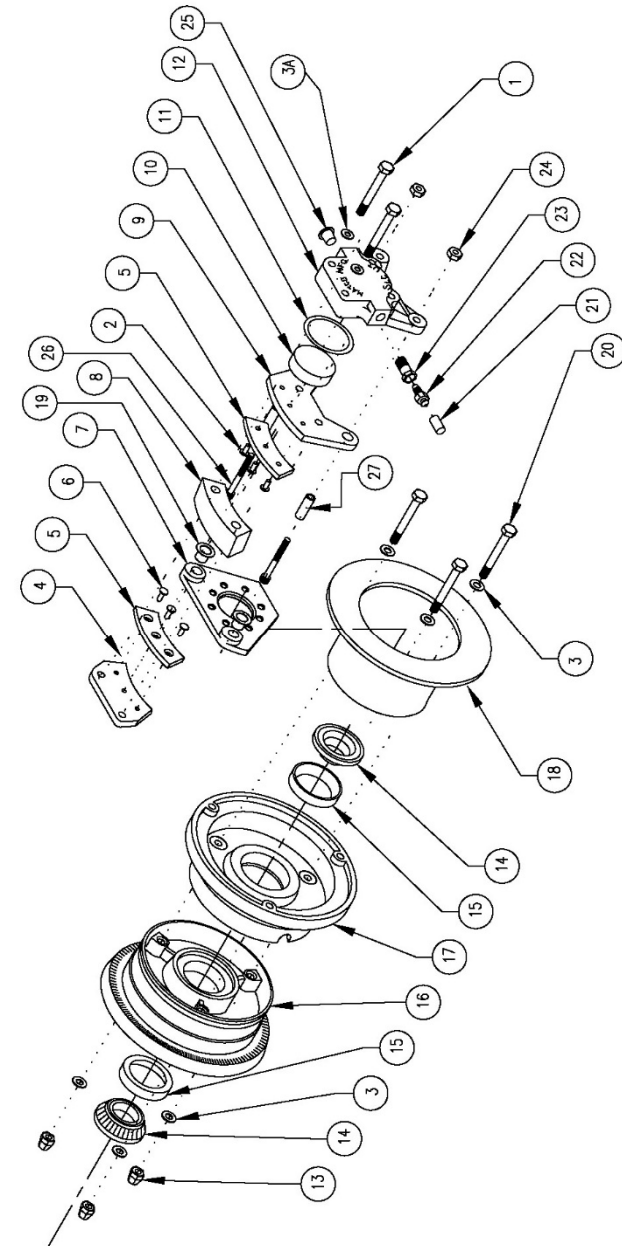

CALIPER HOUSING CONFIGURATIONS

Fig E-2

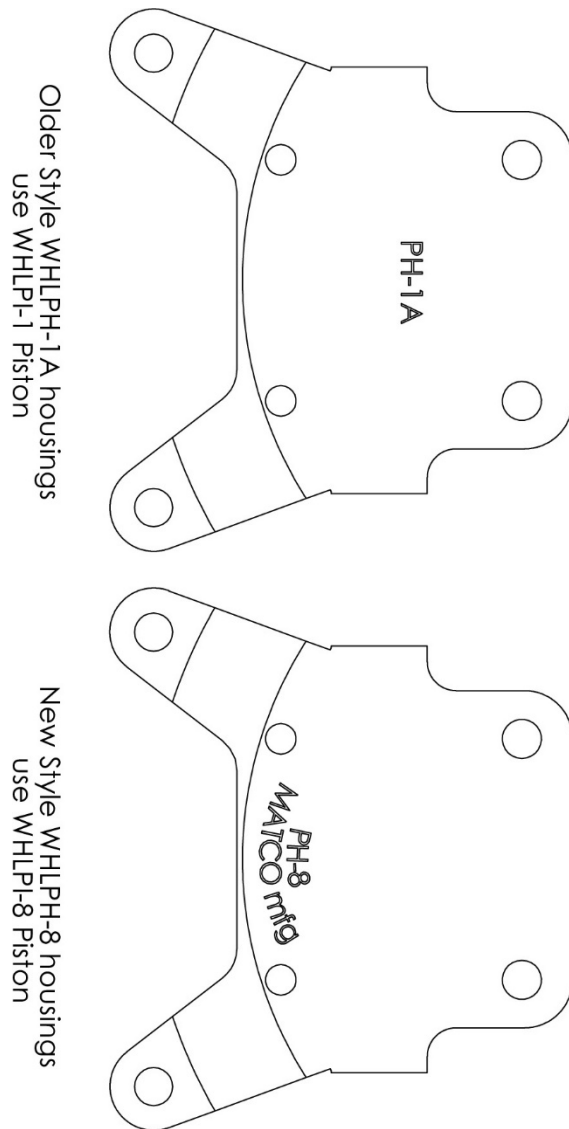

F. BRAKE LINING WEAR LIMITS

To eliminate wear on brake linings beyond design limitation and reduce possible piston damage or fluid leakage, the following information is presented. The M66 series lining (*as found on the WE51 series wheel*) should be replaced when the thickness of the remaining wear material reaches 0.100 IN. (2.54mm) See **Fig F-1**. The M66 lining has a visible wear notch located on the end of the lining that will tell the user when the pad is at the minimum material condition.

F-1 Brake Lining Wear Limits

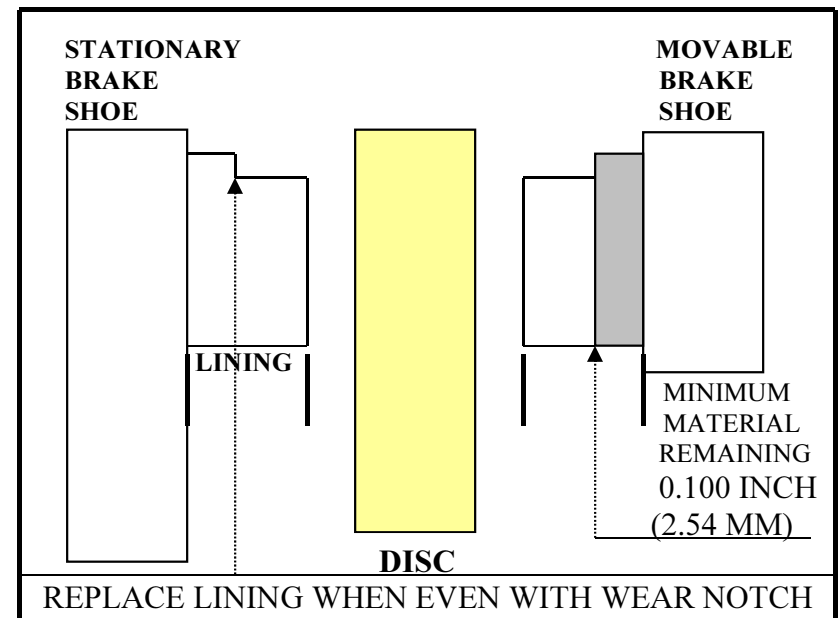

SwiftLine Pad Replacement Program for the WE51

The *Swiftline* Pad Replacement program is designed to:

- Simplify pad replacement on MATCO mfg brakes.
- Eliminate the need to rivet linings, saving maint. & tooling.
- Provide a 20 % discount on reline kits saving you money.

For more information on Swiftline call 801-335-0582

G. BRAKE DISK INSPECTION

The MATCO mfg brake disk will give years of trouble free service under normal field conditions. Conditions such as unimproved fields, standing water, industrial pollution, or frequent use of the aircraft may require more frequent inspection of the brake system and disk in order to prolong the life of the brake linings.

The disk should be checked for wear (**Fig G-1 Dim. "A"**) and for any grooves, deep scratches, excessive pitting or coning of the brake disk. Although coning is rarely a problem with the MATCO mfg disk, if it should occur, coning beyond 0.015 inch (0.381mm) in either direction is cause for replacement.

Isolated grooves up to .030 inch (0.76mm) deep should not be cause for replacement. Any grooving of the disk however, will reduce the service life of the linings.

The WE51 disk is plated for rust prevention. Within a few landings, the plating will wear off where the linings rub against the disk. The remaining portion of the disk will remain plated and corrosion free for an extended period of time under normal use. Nickel plated disks are available from MATCO mfg for those demanding increased corrosion protection and wear.

Rust in varying degrees may form on the exposed portion of the disk. If a powdered rust appears on this surface, one or two braking applications during taxiing should wipe the disk clear. Rust build up beyond this point, may require removal of the disk from the wheel to properly clean both surfaces. A wire brush followed by 220-grit garnet paper should restore the braking surface adequately.

Do not remove plating in areas that are not contacted by the linings.

G-1 Minimum Disc Wear

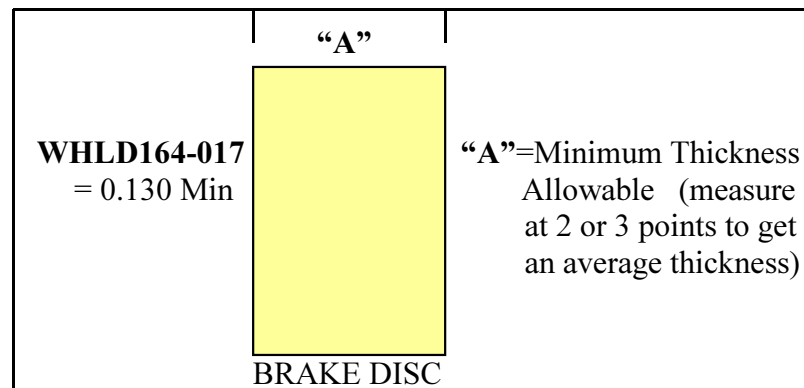

H. BRAKE LINING INSTALLATION

The following instructions offer a guide for properly removing and replacing the WHLM66-106 brake linings.

1. Remove the caliper from the wheel by removing the two MSCAN4-16A bolts that hold it on.
2. Remove old linings by drilling the crimped side of the rivet (Do not use a punch & hammer). Using a #25 drill (0.1495 diameter), drill through rivet taking care to avoid damaging the rivet hole. After drilling crimped edge off rivet, lift old lining and remaining rivet pieces from the brake shoe.
3. Inspect the brake shoe for any bending or other damage that may have occurred during service. A shoe with more than .010 bend should be replaced. Inspect rivet holes to ensure that no damage has occurred during removal.
4. Using a brake relining tool (*MATCO mfg recommends a Threaded Screw Action such as the W404 from Aircraft Tool Supply Co.*) or pneumatic press, replace the lining using the brass rivets shown on the illustrated parts list.
(SEE CONDITIONING SECTION FOR LINING BREAK-IN)

I. MOUNTING THE TIRE & TUBE

NOTE - MATCO mfg wheels are balanced at the factory and stamped with a chevron. The chevron should always be placed adjacent to and directly across from the valve hole. Verify alignment before mounting the tire.

Care should be taken to avoid pinching the tube between the wheel halves when mounting the tire and tube. To avoid this, slightly inflate tube after placing it in the tire. Tire mounting soap may also help. A thin strip of cardboard or poster paper wrapped around the wheel between the mounting half and the tube will help in preventing the tube from being pinched during assembly if it is unusually tight. Another method is to use 3 ratcheting bar clamps evenly spaced around the tire and tube to compress the tire. Compress sufficiently to allow the wheel halves to be seated against each other at the shiplap without contacting the tire. The tube can be visibly inspected. Note in **I-1** that the stem nut rides in the slot between the wheel halves and is not designed to be tightened up against the inside of the wheel. It only acts as a guide in centering the tube.

Fig I-1 Tire Mounting Drawing

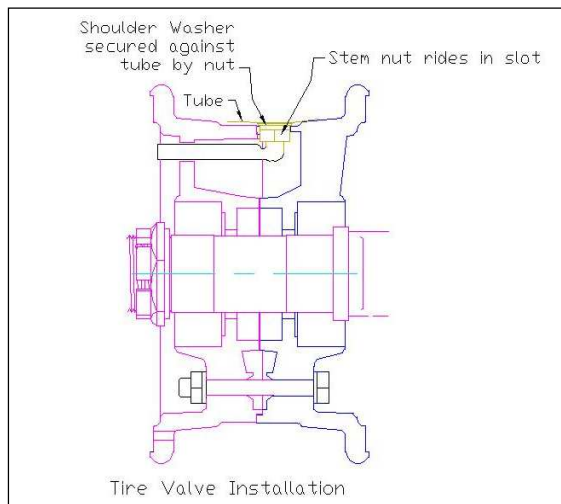

Fig I-2 Tire Mounting Photo



J. WE51 / WE51L WHEEL ASSEMBLY

ASSEMBLY INSTRUCTIONS FOR THE WE51

1. The brake mounting plate (# 7 on assembly drawing) should be spaced from the bearing so that it aligns in the same plane and is parallel with the brake disc. (#18) The tapered roller bearings should be packed with suitable grease. (See Section "N" for lubricants).

IMPORTANT NOTE: Axle Nut Torque

Your MATCO mfg wheel is equipped with tapered roller bearings with integrated grease seals on the bearing cone to ensure the longest possible life. Torque procedures for bearings with this type of seal are different than for bearings without them. A common torquing technique for bearings without seals is to tighten the axle nut until the wheel stops spinning freely then back off to the nearest locking feature.

THIS TECHNIQUE DOES NOT WORK ON BEARINGS WITH AN INTEGRATED SEAL. The reason for the different technique is that the grease seal produces some drag and makes the wheel feel somewhat stiff when rotated. Reducing the axle nut torque until the wheel spins freely will allow the grease seal and the bearing cone to rotate improperly with the wheel. THE CONE MUST NOT ROTATE RELATIVE TO THE AXLE. The higher rolling drag is completely normal for this bearing and allows for longer bearing life since the seal will keep most contaminants out.

Timken specifications state that the two 1.25 inch tapered roller bearings used on the WE51L will produce 18-26 inch pounds of torque (*drag*) when properly installed. A light coating of grease on the seal will help reduce the drag on initial installation. The drag will also reduce after the bearings have been installed and the seal relaxes in the bore.

It is important that the axle nut torque be sufficient to keep the seal from rotating with the wheel. This technique will ensure the longest possible bearing life.

The WE51 uses a mono face seal for lower drag.

2. Tighten the axle nut until all play is out of the assembly. Rotate the wheel back and forth while tightening the nut to help seat the bearings. When all play is out and the wheel rotates freely, tighten to the next slot and insert cotter pin.
3. The rubber seal on the tapered roller bearing should remain stationary while the wheel rotates around it. If the seal is spinning on the axle, tighten the nut further until the seal stops spinning with the wheel. (See Note Above).
4. All o-rings in the brake and master cylinder assembly are Buna Nitrile and are NOT compatible with automotive glycol based brake fluids.

NOTE - Use only red aircraft fluid Mil-H-5606 or other suitable petroleum or silicon-based fluids.

5. The ideal mounting position for the brake caliper is on the trailing side of the wheel with the inlet and bleeder valve in a vertical axis. However, the caliper may be mounted at any location as long as air can be properly bled from the system.
6. When using MATCO mfg bolt on axles, they can be shimmed for toe-in or toe-out conditions, and spaced out from the wheel if necessary for the brake disk attachment screws to clear the landing gear leg. MATCO mfg manufactures aluminum axles in black anodized 2024-T351 aluminum.

K. WHEEL ASSY. TORQUE VALUES

DWG #	PART NUMBER	TORQUE VALUE (INCH LBS)
13	MSCAN363-428	100 IN. Lbs.
24	MSC.25-28CRLOCK	100 IN. Lbs.
1	MSCAN4-16A	100 IN. Lbs.

L. CALIPER ALIGNMENT

The brake caliper must be positioned properly when assembled on the axle. When using MATCO mfg. axle WHLA1A, the caliper alignment is assured because the bearing stops are machined into the axle. The WE51L wheel can also be mounted on a straight 1.25-inch axle. When using a straight axle, the required caliper spacing is shown below.

Fig L-1 Caliper Alignments

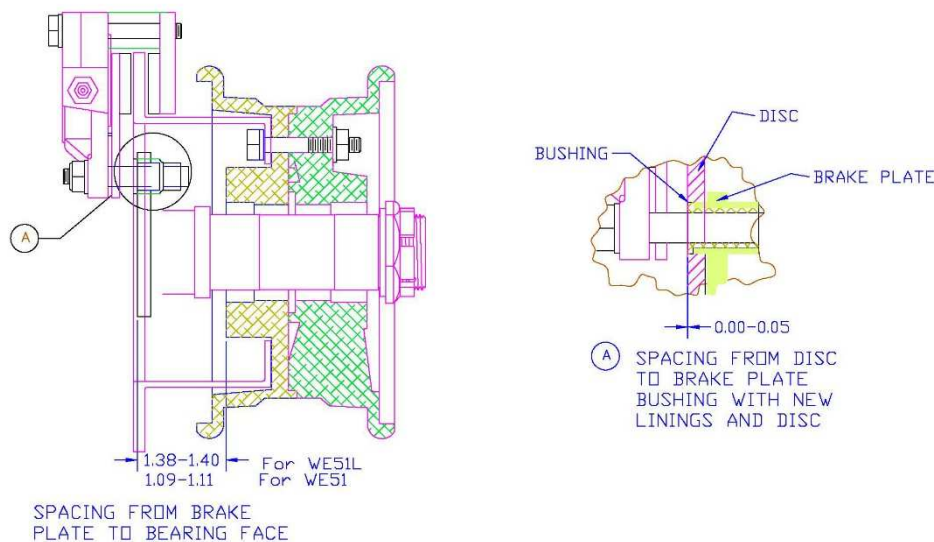

M. BLEEDING THE BRAKE SYSTEM

1. Open the brake bleeder valve slightly (# 22 on the assembly drawing) to facilitate bleeding of air from the system.
2. Attach a tube from the nozzle of a bleeder can (*also called a hand oiler*) of brake fluid, to the top of the brake bleeder valve. Pump the handle until oil flows bubble free from service hose before attaching.
3. Make sure that the master cylinder shaft is fully extended to open up the internal bypass valve.
4. Inject brake fluid (Mil-H-5606) or equivalent, into the puck housing and continue injecting until the fluid travels through the system into the master cylinder.
5. Air in the system will be pushed up and out in to the master cylinder **ONLY IF** the master cylinder or remote reservoir is at the highest point in the system, and there are no loops in the brake lines.
6. Fluid should be pushed through the system until it reaches approximately $\frac{1}{4}$ inch from the top of the master cylinder or remote reservoir
7. Close the brake bleeder valve, and remove the service hose.
8. GENTLY stroke each cylinder. If the brake system is free of air, the brake pedal should feel firm and not spongy. If not, repeat steps 1 through 7 until system is free of trapped air.
9. Fluid leakage from the top of the MCMC-5 master cylinder during operation indicates too high a fluid level.
10. Ensure that all drilled bolts are torqued and secured.

NOTE - The MCMC-5 is NOT approved for inverted flight.

Fig M-2 Vacuum Bleeding Brake Schematic

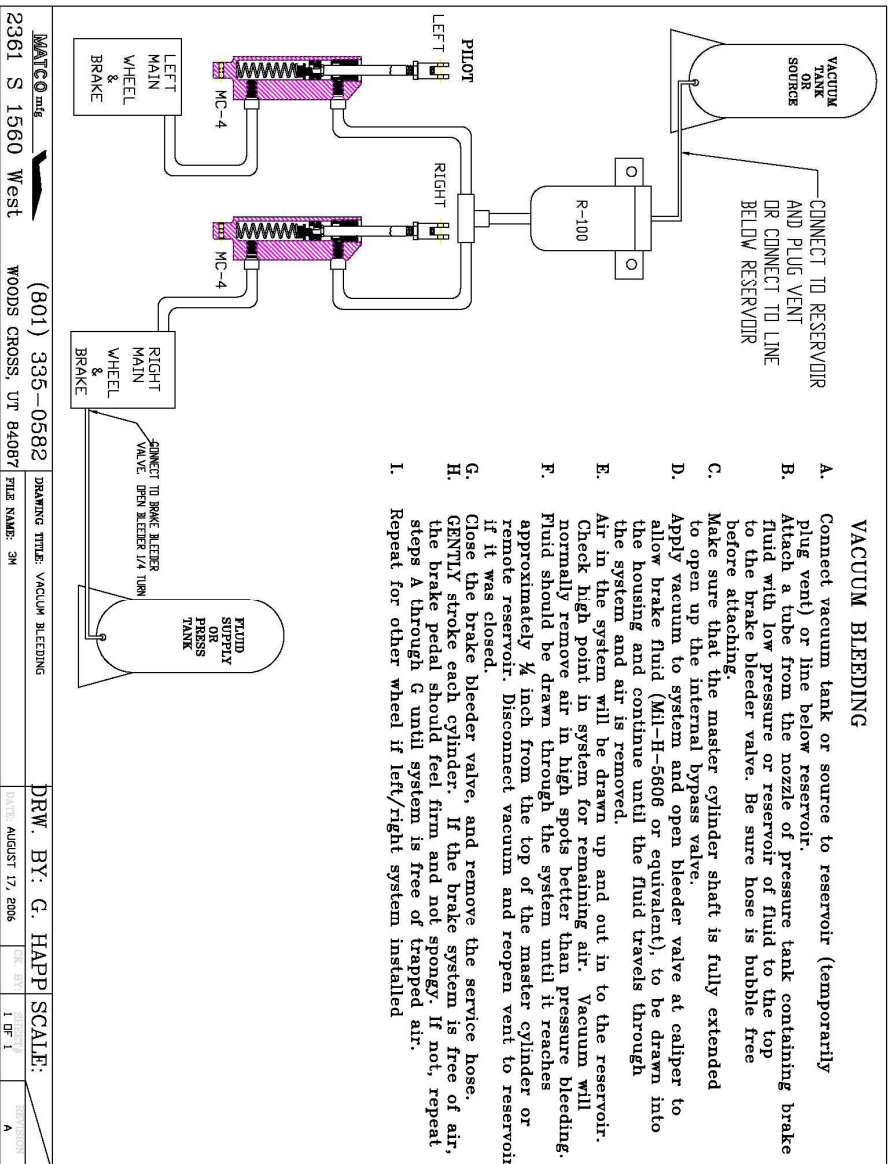
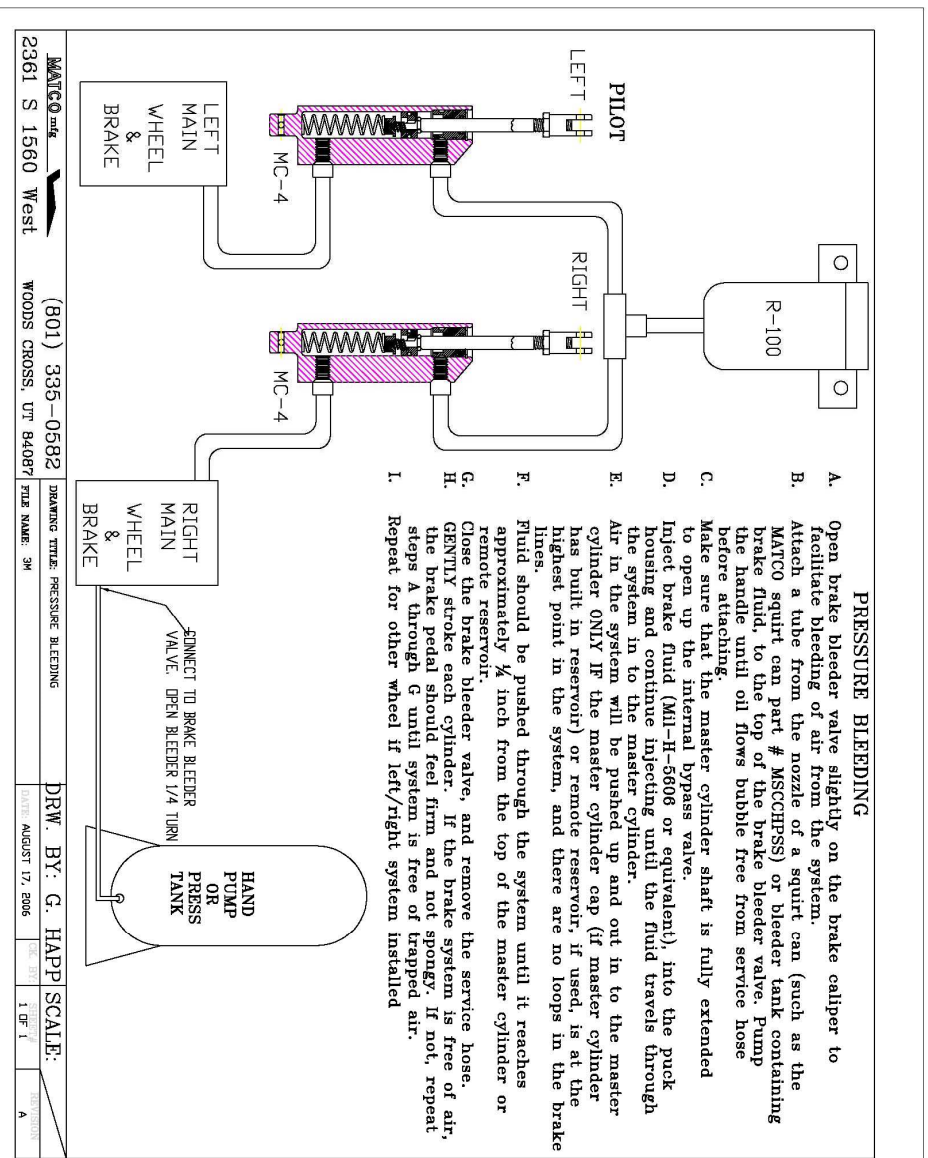

Fig M-1 Pressure Bleeding Brake Schematic



N. CONDITIONING PROCEDURES

NOTE - It is important to condition the new linings after installation to obtain maximum service life and performance. The procedures below describe when and how this should be done.

1. After the linings have been installed, apply brake pressure during high throttle static run-up. Note RPM at creep if any occurs.
2. Perform 2-3 high-speed taxi snubs to generate 300-400 degrees at brake pads and rotor by accelerating the aircraft to 30-40 mph. Remove power and apply firm braking pressure until slowed to 5 mph and release pressure. Do not bring aircraft to a complete stop during the taxi snubs. After accomplishing the snubs, do not drag the brakes. Allow the aircraft to roll as brake free as practicable until back to the tie down area. Avoid stopping the aircraft completely as much as practicable and park with brake pressure off
3. Allow brakes to cool for 10-15 minutes.
4. Repeat step one and note RPM at creep if any occurs. There should be a noticeable increase in holding torque.
5. Repeat steps 1 through 3 if necessary.

NOTE - Forward movement of the aircraft while testing brakes, could be caused by skidding and not brake malfunction. Use caution when breaking heavy on aircraft with a tailwheel as it could cause the tail to lift from the ground.

Conditioning removes high spots, and creates a layer of glazed material (shiny appearance) at the disk surface. Normal braking will produce enough heat to maintain glazing during the life of the lining. Glazing can be worn off during light use such as taxiing and occasional reconditioning may be required.

O. MAXIMIZING BRAKE OUTPUT

GETTING YOUR PEDAL GEOMETRY RIGHT

BRAKE SPECIFICATIONS

ENERGY RATING

All MATCO mfg. brakes have two specified ratings. The first is the energy rating which specifies the energy capacity of the brake. This value is used in selecting a brake that will be able to absorb the kinetic energy of the aircraft under the designers specified maximum energy condition (*generally maximum aircraft weight at a velocity above stall speed*). The energy rating is determined by the disc weight. Exceeding the energy capacity of a braking system leads to excessive disc temperatures. This can cause low friction coefficients and reduce brake torque and aircraft deceleration. Permanent damage to the disc can result in the form of warping or loss of corrosion protection.

BRAKE TORQUE

The second rating is for brake torque. The rated torque value is used to determine the deceleration and static torque for engine run-up that will be provided by the brake. A braking system using the same disc can have one energy rating and several torque ratings. This is possible by using different caliper configurations on the same disc. For example a braking system using a single caliper on a disc with a 189K ft-lb rating may have a torque rating of 1980 in-lb. The same braking system using two calipers would have the same energy rating of 189K ft-lb but would have a torque rating of 3960 in-lb. MATCO mfg offers its customers a wide range of caliper configurations and disc sizes to allow for meeting both energy and torque requirements for their aircraft.

GETTING THE RATED TORQUE

The rated torque value assumes a nominally conditioned brake pad (*see pad conditioning procedures section 'L'*), rated pressure applied to the brake, free floating calipers, and pad contact on both sides of the disc. Brake pad conditioning allows a glaze to form on the pads and provides the highest friction coefficient and drag force. MATCO mfg brake torque ratings are based on 450 psi applied pressure. Pressures below this value will generate proportionally lower torque. Pressures above this value will provide higher torque although pressures above 600 psi generally cause caliper deflections that reduce the torque increase. The torque rating assumes that all caliper force is used to squeeze the brake pads against the disc. If the caliper does not float freely, it is possible that only one side of the disc surface may be contacted resulting in 50% loss of torque.

GET THE PRESSURE RIGHT

Assuming the calipers are properly mounted so that the pads make contact on both sides of the disc (*both new and worn*) and are maintained so that the calipers float freely, the most common reason for under performance of the brakes is low pressure. MATCO mfg. Brakes need 450 psi to achieve their rated torque. Additional calipers can be added to get higher torque at a lower pressure but it is often more weight efficient to modify the hydraulic system pedal geometry to generate high pressures. Systems using hand or foot operated master cylinders require a minimum of 2.5 to 1 mechanical advantage when using master cylinder, MC, like the MC-4 or MC-5 which have .625 inch diameter pistons. (*Systems using MC-4 or MC-5 with intensifiers have .500-inch pistons and require a 1.6 to 1 mechanical advantage*). Mechanical advantage, MA, is the ratio of the force applied to the master cylinder shaft divided by the force applied by the hand or foot. **O-1** shows two examples of pedal geometry.

The first has an MA of 1 to 1 since the distance from the applied load to the pivot point is the same as the distance to the MC and is undesirable. The second shows a more favorable configuration that will easily provide the required pressure to the brakes with moderate toe force.

It is often necessary to keep the foot pedal shorter than that shown in **Fig O-1**. An alternate geometry is shown in **Fig O-2**. This design would utilize a fork arrangement on the MC connection to allow clearance of the MC body and then a short linkage to the MC connect point. A design common to many aircraft uses linkage as shown in **Fig O-3**. This design also allows for a shorter brake pedal but has a major disadvantage. This linkage can be configured to have a proper MA in the start position (with the master cylinder fully extended). The MA varies with rotation however, as shown in **Fig.2 of Fig O-3**, a 15 degree rotation of the linkage reduces the MA at the start position from 1.5 to 1 down to only 1.12 to 1. In actual operation, this has the effect of causing a nearly constant brake torque even though increasing force is applied. For example, if the geometry is set for an initial MA 2.5 to 1. In the start position and the pilot applies pedal force, the MC will begin to stroke as pressure builds. As the rotation occurs, the MA decreases. If there is any air in the brake lines or if there are long brake line runs, hydraulic system expansion will occur as pressure increases requiring more MC stroke. If the pilot applies more pedal force, more MC stroke occurs, and the MA decreases further. Even though the pilot has now increased his pedal force, the force applied to the MC will be only marginally increased because more rotation will result and cause a further decrease in MA. A geometry like that in **Fig O-2** will provide the same reduced pedal height and is not prone to the effect of rotation since the MC is essentially connected to the brake pedal pivot. **Fig O-4** illustrates the benefit of pivot connect geometry during rotation. The MA remains virtually unchanged for expected rotation angles and results in a linear pressure increase with applied pedal force.

HEEL BRAKES

A common means of providing pilots with differential braking brakes is to use heel brakes. The same design requirements exist for the MA of a system using heel brakes as for toe brakes. It is not uncommon to see MC's configured to allow the pilot to apply heel force directly to the MC by means of a pad or a button connected to the end of the shaft.

This configuration is shown in **Fig.1 of Fig O-5**. The MA of this system is 1 to 1 and produces very low pressure for reasonable heel force.

Perhaps a larger concern however is the potential for causing damage to the MC. The MC is designed to accept loads applied along the length of the shaft. Loads applied off axis or perpendicular to the shaft cause bending moments in the MC shaft that it is not designed for. Damage to the MC end gland, or bending of the MC shaft may result if the off axis brakes is shown in **Fig.2** of **Fig O-5**. This system uses a short linkage connected to the MC that provides the 2.5 to 1 MA while insuring that loads will be applied along the length of the MC and prevent any damage during actuation.

CONCLUSION

Like any system on an aircraft, the hydraulic system has many engineering options for providing the necessary requirements. The systems common on light aircraft must be engineered to provide adequate pressure to the brakes to achieve the rated torque. MATCO mfg brakes require 450 psi to achieve the rated torque. The pedal geometry whether hand, toe, or heel operated, requires a mechanical advantage of at least 2.5 to 1. This allows the pilot to easily generate the required 450-psi with moderate applied force. Pivot connected geometry provides the best means of accomplishing this requirement without the problem of rotational effect that reduces mechanical advantage.

PEDAL GEOMETRY / POOR & MINIMUM

Fig O-1

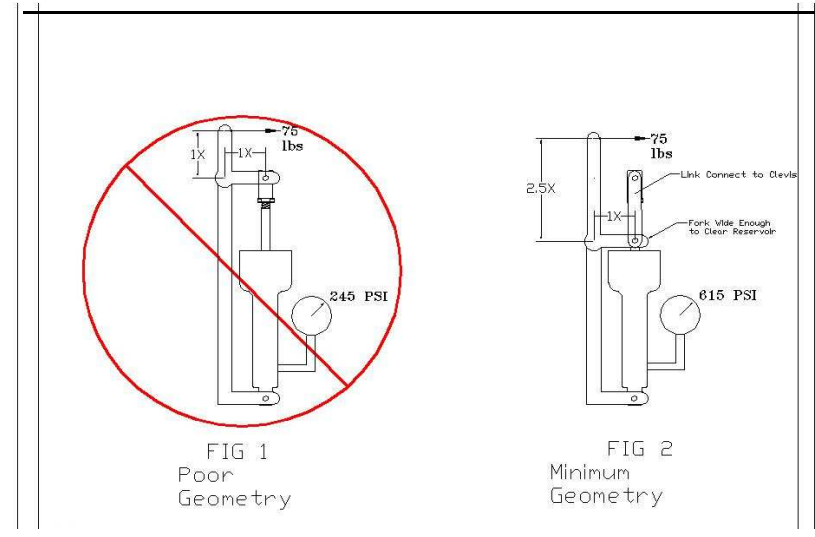

PEDAL GEOMETRY / POOR & MINIMUM

Fig O-2

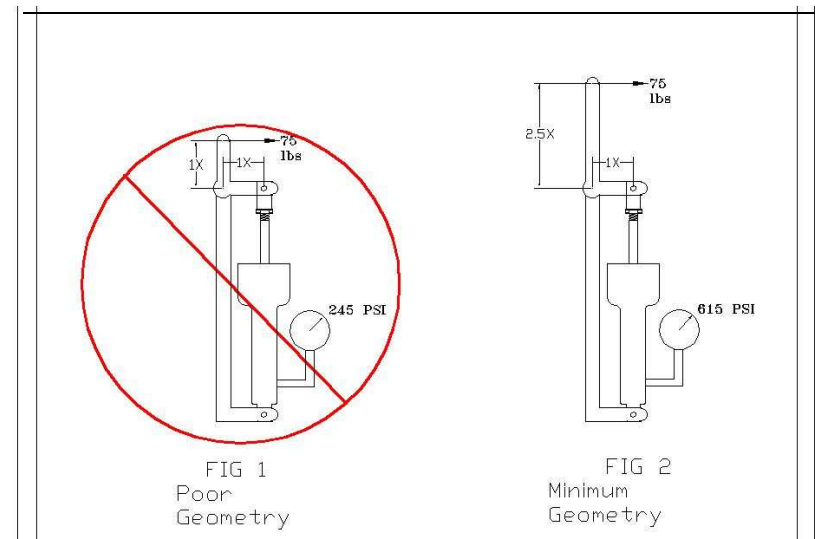

PEDAL GEOMETRY / MECHANICAL ADVANTAGE

Fig O-3

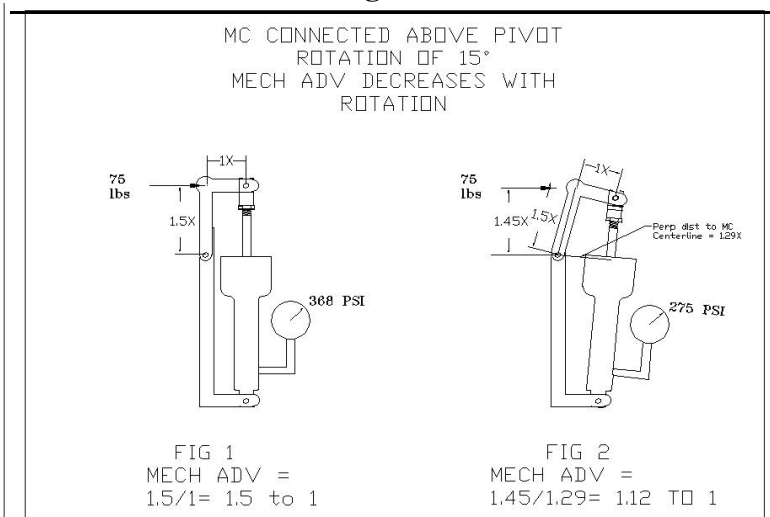

PEDAL GEOMETRY / HEEL BRAKES

Fig O-5

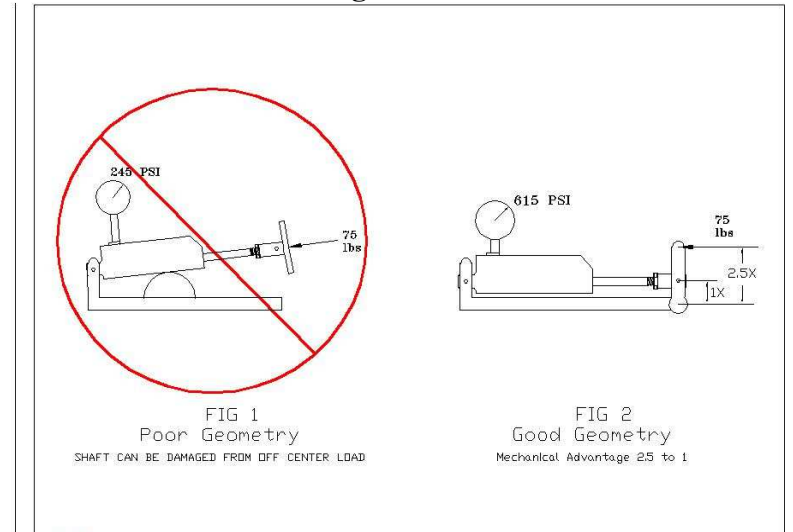

PEDAL GEOMETRY / PIVOT CONNECT

Fig O-4

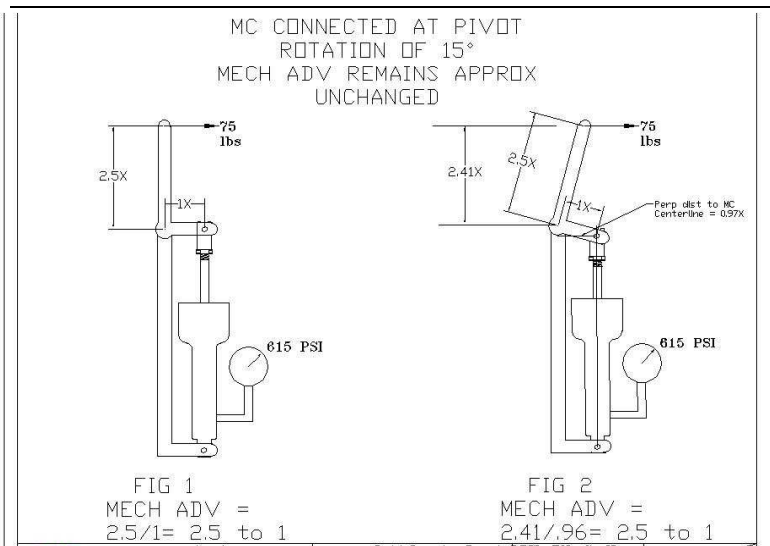

P. LUBRICANTS

ELASTOMERIC COMPOUND LUBRICANTS

HYDRAULICS: MIL-H-5606 / MIL-H-83282
Or equivalent (Red Oils)

PETROLEUM LUBRICANTS

WHEEL BEARINGS: MIL-G-81322
MOBIL 28
MOBIL SHC-100
AEROSHELL 22
Or equivalent lubricants

AMPHIBIOUS: HCF Grease P/N 605
BG Products, Wichita, KS.

THREAD SEALANT

TAPERED PIPE THREADS: Loctite 567, or equivalent

Q. TECHNICAL ASSISTANCE

For technical information, product matching,
and helpful hints, see our website at:

www.matcomfg.com

E-mail our Technical Service Manager
for specific information at:

tech@matcomfg.com

TECHNICAL ASSISTANCE

To speak with someone in person about specific products or to find
answers to technical questions, please contact us at

TECHNICAL HOTLINE

801-335-0582

OR **FAX** US AT **801-335-0581**

Technical Support Disclaimer:

While we at MATCO mfg. strive to ensure that the advice/information provided through our support is correct, MATCO mfg. does not accept any responsibility for errors or omissions. Any advice or information that MATCO mfg. gives you, via any form of communication is not a guarantee that it will correct your problem. It is only offered as assistance to you.

MATCO mfg. will not be held responsible for any loss or damage as a result of our advice or information supplied.

NORD-LOCK Washers

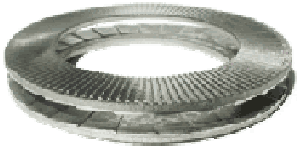

NORD-LOCK is a pair of washers with a wedge-locking action meeting DIN 25201 which is a unique method using tension instead of friction. The rise of the cams between the NORD-LOCK washers is greater than the pitch of the bolt. In addition, there are radial teeth on the opposite side. The washers are installed in pairs, cam face to cam face.

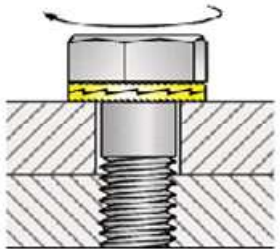

When the bolt and/or nut is tightened the teeth grip and seat the mating surfaces. The NORD-LOCK washer is locked in place, allowing movement only across the face of the cams. Any attempt from the bolt/nut to rotate loose is blocked by the wedge effect of the cams.

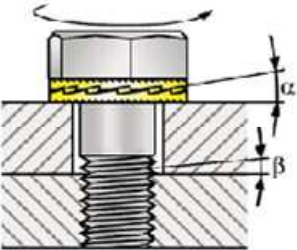

Here you see what happens when a bolt is untightened with a wrench. The pair of washers expand more than the corresponding pitch of the thread allows the bolt/nut to rise.

NORD-LOCK washers positively lock the fastener in a joint which is subjected to any kind of vibration or dynamic loads.

REPLACE the NORD-LOCK washers if the cam surface is worn and corners are rounded or if the pair does not seat cleanly against each other

NORDLOCK TORQUE VALUES

MSCNL5 #10 80 in-lb MSCNL1/4 1/4" Shoulder 100 in-lb
 MSCNLX6 1/4" All-Thread 100 in-lb MSCNL8 5/16" 120 in-lb

Verify bolt bottoms against surface before installing NordLock

MY AIRCRAFT INFORMATION

WHEEL INFORMATION

WHEEL MODEL # _____

(Pages 5-7) BRAKE ASSY _____

(Pages 5-7) BRAKE LININGS WHLM66-106

BRAKE FLUID MIL-H-5606 or equivalent _____

(Page 5-7) BRAKE DISC WHL D164-017

(Page 12) MIN DISC THICKNESS 0.130

NOTES
