

ITEM #	Part Number	Description	QTY.
1	MSC.11x1.5COTTERPI	PIN, COTTER ZINC	2
2	MSC.62-18HEXNUT/SL	NUT, HEX SLOTTED	2
3	MSCU321608	WASHER, BELLEVILLE	1
4	MSC.625SAE	WASHER, 5/8	2
5	MSCU625-0210	WASHER, CURVED	1
6	MSC.62-18X4.35(A)	AXLE, VERTICAL TAILWHEEL	1
7	MSCVC-250-8	COVER, BLEEDER BLK	1
8	WHLTWBE1.5	BASE, TAIL WHEEL	1
9	WHLTDW-8FHD	FORK ASSEMBLY, 8FHD	1
10	MSCMC7-4	FITTING, GREASE	1
11	WHLBSP4	SPACER, 4"/UL BRAKE	2
12	MSCAN960-10	WASHER, AN960	4
13	WHLTW-4	WASHER, BRONZE	1
14	MSCAN3-6	BOLT, HEX DRILLED	2
15	MSC.25-20x.50SHCS	BOLT, SHCS .25-20X.50	1
16	MSCB0375-020	WASHER, BELLEVILLE	2
17	WHLT-02	ARM, TAIL WHEEL	1
18	MSC.750x.190x.062W	WASHER, BRONZE	2
19	WHLT-03	Wing, Tail Wheel	2
20	MSCAN310-3	NUT, CASTLE	2
21	MSC.0625X.50COTTER	PIN, COTTER ZINC	2
22	WHLTW-21	BUSHING	1
23	WHLTW-19	BUSHING, HAT	3
24	MSC.50-13X4.50HH	BOLT, HEX	1
25	WHLT8DSL	SPACER, T8D	2
26	WHLTW40EE	ASSEMBLY, 4" TW	1
27	WHLT8SL	SPACER, T8SL	1
28	MSCAN960-816L	WASHER	1
29	MSC.50-13NYLOCK	NUT, NYLOCK	1
30	TIRT2.80/2.50-4	TIRE, 2.80/2.50-4	1
31	TIRTU2.80-4	TUBE, 2.80/2.50-4	1

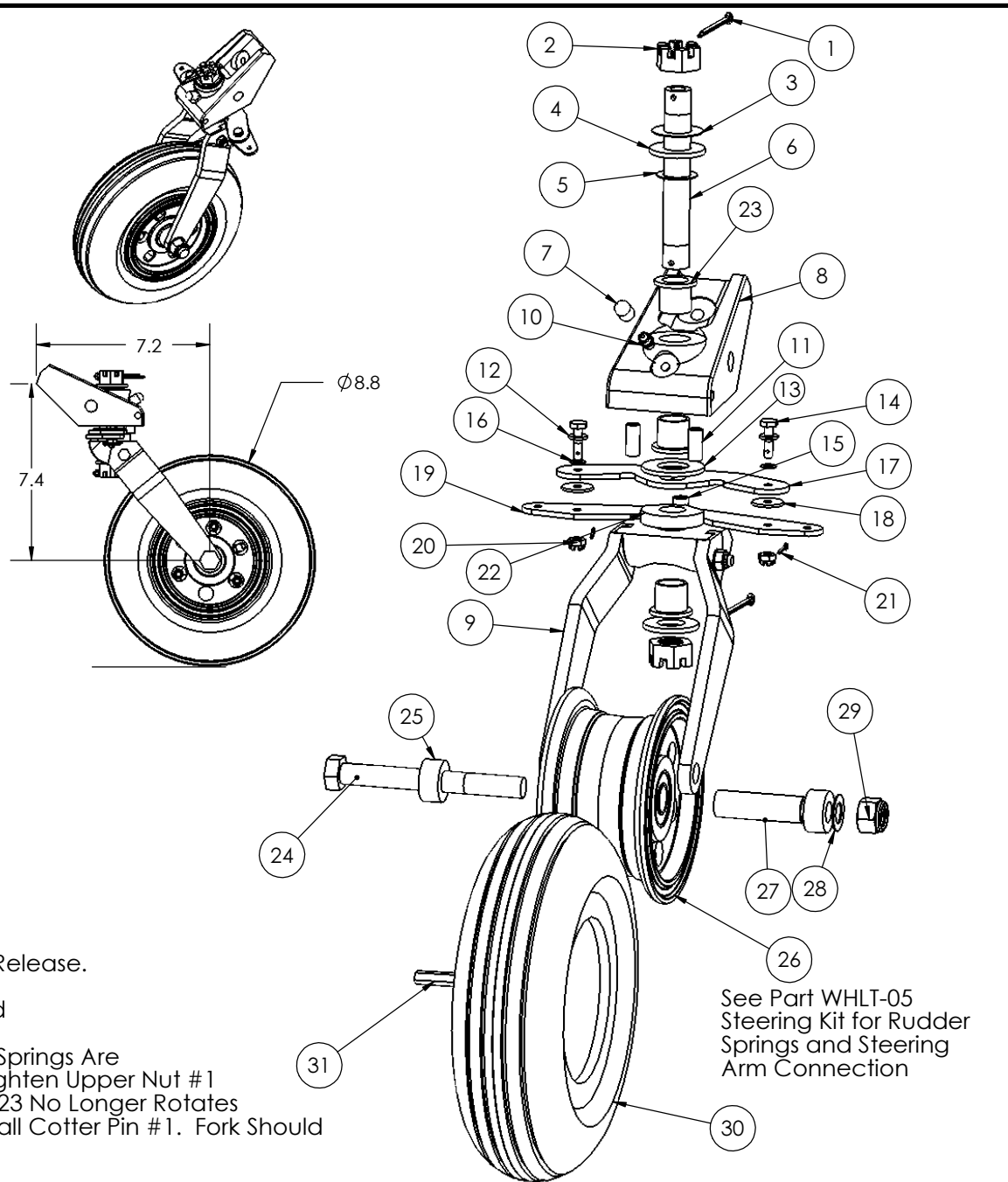

Note: Alternate Wing Available to Provide Earlier Steering Release.

Release with Standard WHLT-03 = +/- 45 Deg

Release with Optional WHLT-03A = +/- 25 Deg (May be Hand

Ground to Release from 25 to 50 Deg)

TO SET PRELOAD IN VERTICAL AXLE #6: Be certain #3 & #5 Springs Are

Installed. Seat Lower Nut #2 Fully & Insert Cotter Pin #1. Tighten Upper Nut #1

Slowly Until All Freeplay of Springs are removed and Fork #23 No Longer Rotates

Freely. Loosen Upper Nut #2 1-4 Locking Features and Install Cotter Pin #1. Fork Should

Rotate With Resistance Around Complete Rotation.

See Part WHLT-05  
Steering Kit for Rudder  
Springs and Steering  
Arm Connection

**MATCO mfg**



2361 S 1560 West  
Woods Cross, UT 84087

NOMENCLATURE  
TAILWHEEL, 8" Dual Fork

PART NUMBER  
WHLT-8D

SCALE  
1:4

TOLERANCES  
(EXCEPT AS NOTED)

DRAWN BY  
George R. Happ

FINISH

DATE  
11/10/2016

DRAWING NO.  
TAIL/3D-T8D

CHECKED BY

REVISION  
D

Est Wt. (lb)  
6.49

DO NOT SCALE DRAWING

LINEAR .XX = + .03

.XXX = + .01

ANGULAR + 1/2

CONCENTRIC + .01

SHEET 1 OF 1  
SHEET SIZE A