

# **MATCO mfg**

## **Wheels & Brakes**

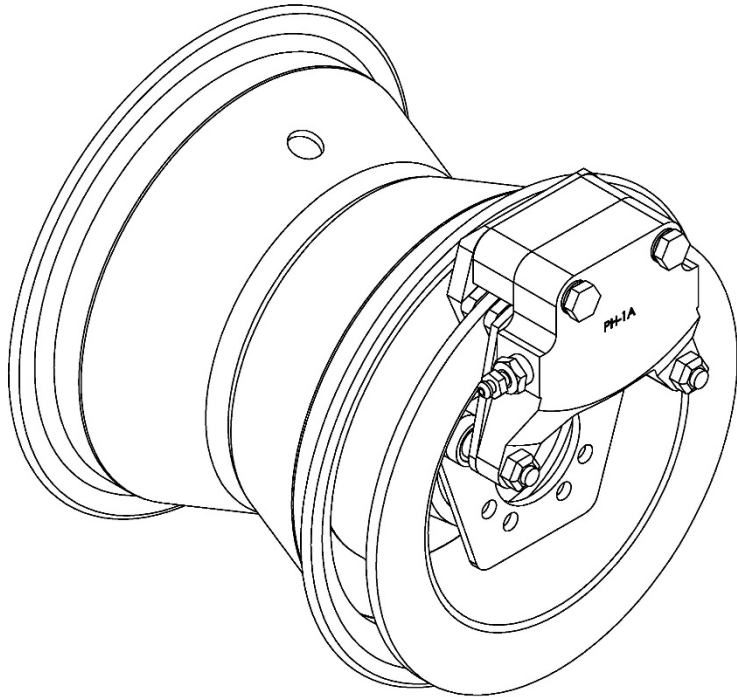

### **MHE6B & MHE6B-SC**

#### **External Caliper**

#### **6" E-Series**

#### **Wheel and Brake**

### **Technical Service Bulletin**

## **A. MHE6B & MHE6B-SC 6" E-SERIES WHEEL**

### **Table of Contents**

	<b>Subject</b>	<b>Page</b>
<b>A</b>	Technical Information	<b>2</b>
<b>B</b>	MHE6B & MHE6B-SC – Parts List	<b>3</b>
<b>D</b>	Brake Lining Wear Limits	<b>7</b>
<b>E</b>	Brake Disc Inspection	<b>8</b>
<b>F</b>	Brake Lining Installation	<b>9</b>
<b>G</b>	Mounting the Tire & Tube	<b>10</b>
<b>H</b>	Tubeless Kit Installation	<b>10</b>
<b>I</b>	Wheel Assembly Instructions	<b>12</b>
<b>J</b>	Wheel Torque Values	<b>16</b>
<b>K</b>	Caliper Alignment	<b>16</b>
<b>L</b>	Bleeding the Brake System	<b>18</b>
<b>M</b>	Conditioning Procedures	<b>21</b>
<b>N</b>	Maximizing Brake Output	<b>22</b>
<b>O</b>	Lubricants	<b>29</b>
<b>P</b>	Technical Support	<b>30</b>
	Quick Reference	<b>32</b>
	<b>Drawings &amp; Diagrams</b>	<b>Page</b>
<b>C-1</b>	Brake Assembly Drawing	<b>4</b>
<b>C-2</b>	Caliper Housing Configuration	<b>5</b>
<b>C-3</b>	Z Caliper Housing Configuration	<b>6</b>
<b>D-1</b>	Brake Lining Wear Limits	<b>7</b>
<b>E-1</b>	Minimum Disc Wear	<b>9</b>
<b>H-1</b>	Tubeless Kit Installation	<b>11</b>
<b>K-1</b>	Caliper Alignment	<b>17</b>
<b>L-1</b>	Pressure Bleeding	<b>19</b>
<b>L-2</b>	Vacuum Bleeding	<b>20</b>
<b>Dia 1</b>	Pedal Geometry	<b>26</b>
<b>Dia 2</b>	Pedal Geometry	<b>26</b>
<b>Dia 3</b>	Pedal Geometry	<b>27</b>
<b>Dia 4</b>	Pivot Connect Geometry	<b>27</b>
<b>Dia 5</b>	Heel Brake Geometry	<b>28</b>
<b>P-1</b>	Nord-Lock Washer	<b>31</b>

## DIMENSIONS

The MHE6B is an 'E' series SIX inch wheel with a width of 6.20 inches and 1.31 inch caliper spacing. 'E' series wheels utilize external calipers for easy maintenance. Bearing spacing is 2.71 inches and axle spacing is 0.68 inches. Total weight of the wheel and brake assembly is 6.6 pounds including bearing and brake plate. Bearing axle diameter is 1.25 inches.

## FEATURES

The MHE6B wheel utilizes CNC spun aluminum alloy wheel halves for its superior strength, lightweight, and resistance to corrosion that is inherently found in magnesium wheels. The MHE6B wheel uses a 1.25 inch tapered roller bearing, designed and rigorously tested for long life and resistance to bearing fatigue. The "E" series wheel features a single piston brake assembly with an external caliper for easy maintenance. Caliper removal is accomplished by removing two bolts giving easy access to the linings. Al-Ni-Brz bushings are used on 'E' series wheels to ensure smooth caliper travel. The CNC spun wheel halves offer a precision surface for use with a variety of commercial tires. The MHE6B can be fitted with the A3A or A3C bolt on axle, offering easy installation. Both axles are made of black anodized 6061-T6 alloys.

## PERFORMANCE

The MH6EB & MHE6B-SC wheels are designed for the following performance standards:

Static Capacity	700 lbs
Limit	2,100 lbs
Max Accelerate/Stop (Kinetic Energy)	118,121 foot-lbs
Torque Rating	2,085 in-lbs at 450 psi

## TIRE & TUBE

Precision machining on the MHE6B wheel allows for the use of a variety of tires to include Goodyear, McCreary, Michelin, and many 6" industrial tires.

## **B. MHE6B & MHE6B-SC PARTS LIST**

#	PART NAME	QTY	MATCO PART #
1	BOLT, HEX HEAD	2	MSCAN4-16A
2	RIVET	3	MSCAN4-4
3	WASHER	2	MSCNL1/4
3A	WASHER	3	MSCNLX6
4	STATIONARY BRAKE SHOE	1	WHLBSE5
5	LINING	2	WHLM66-106
6	BRASS RIVET	3	MSC4-6
7	BRAKE PLATE E1.38 *	1	WHLBP AE1.38
8	SPACER	1	WHLBSPE5
9	MOVABLE BRAKE SHOE	1	WHLMBSE5
10	SEE FIGURE C-2 C-3	1	PISTON
11	O-RING BUNA-N	1	MSC2-222
12	SEE FIGURE C-2 C-3	1	CALIPER HOUSING
13	Not Replaceable	-	See #7
14	BOLT, SHCS	2	MSC.25-20X1.75SHCS
15	CAPLUG	1	MSC-2X
16	LOCK NUT	2	MSC.25-20CRLOCK
17	BRAKE BLEEDER SEAT	1	MSCBBS(S) &MSC2-008
18	BRAKE BLEEDER VALVE	1	MSCF6446-S
19	DUST PLUG	1	MSC.234-X.50IL
20	BOLT, SHCS	3	MSC.31-18X.875SHCS
21	WASHER	9	MSCAN960-516L
22	BOLT, SHCS	3	MSC.31-18X1.25SHCS
23	BEARING RACE, 1.25	2	WHLLM67010
24	HUB, for 1.25 BEARING	1	MH62-125
25	WHEEL, BACK HALF	1	MH62-6-25N(S)
26	BRAKE DISC, 5" E SERIES	1	WHLD164-017
27	O-RING BUNA-N	1	MSC2-342 (Optional)
28	WHEEL, VALVE HALF	1	MH62-6-25H(S)
29	LOCK NUT	6	MSC.31-18NYLOCK
30	VALVE STEM	1	MSC412S (Optional)
31	ROLLER BEARING 1.25	2	WHLLM6700LA
32	SPACER	2	WHLBSP6
33	BOLT, BHCS	3	MSC.25-20X.75BHCS

\*NOTE: Wheel MHE6B-SC uses brake plate WHLBPA MHE1.38  
New bleeder seat MSCBBS(S) uses MSC2-008 O-Ring

# C. BRAKE ASSEMBLY DRAWING

Figure C-1

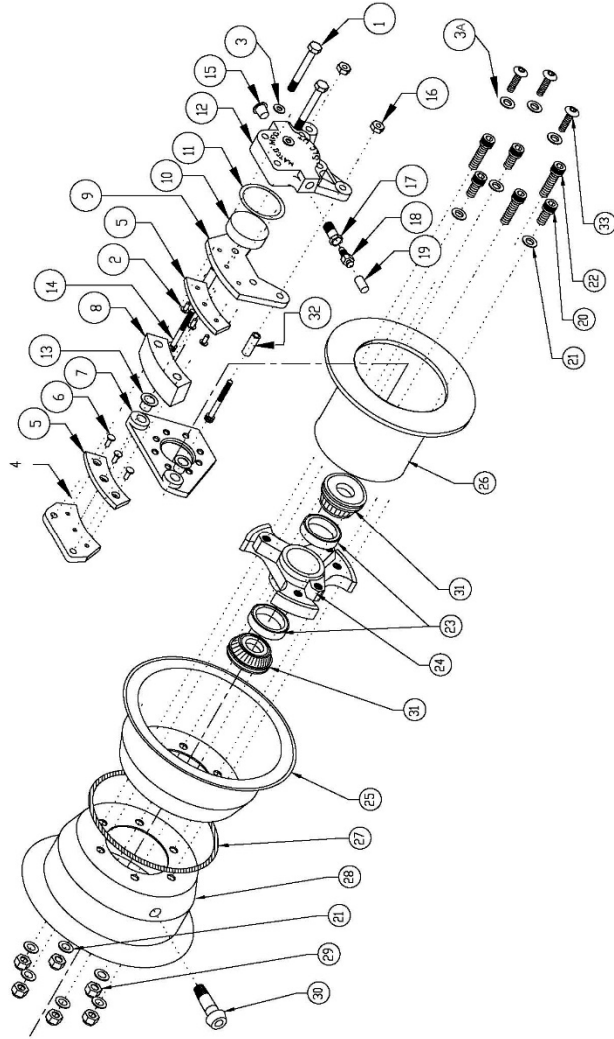

# CALIPER HOUSING CONFIGURATION

Figure C-2

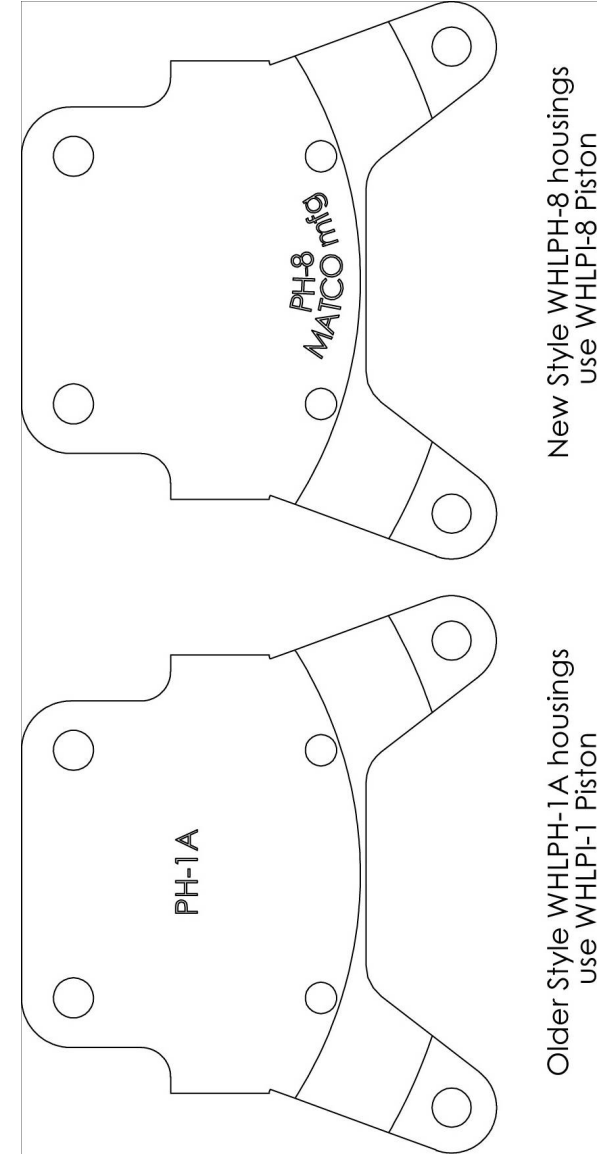

## Z CALIPER HOUSING CONFIGURATION

Figure C-3

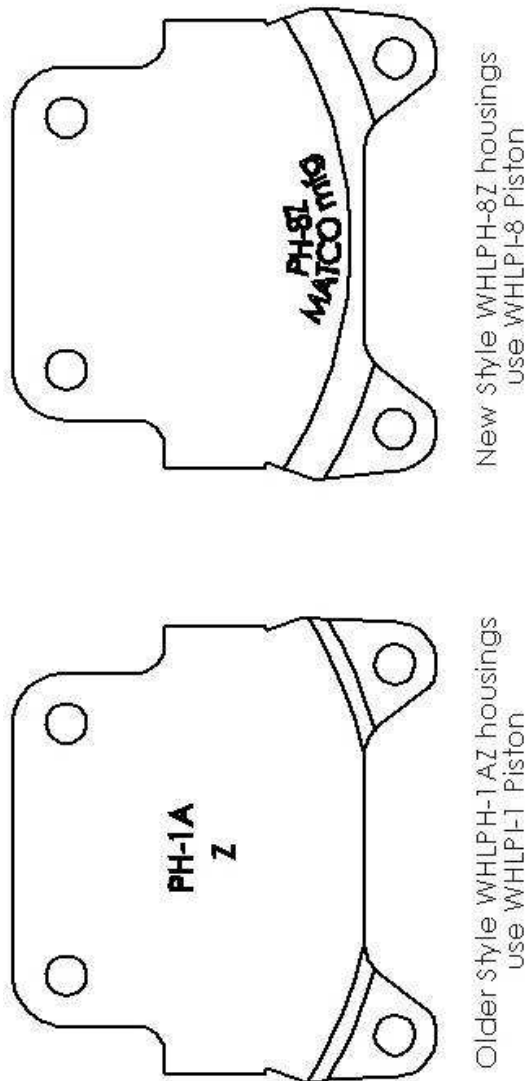

## D. BRAKE LINING WEAR LIMITS

To eliminate wear on brake linings beyond design limitation and reduce possible piston damage or fluid leakage, the following information is presented. The M66 series lining (as found on the MHE6B series wheel) should be replaced when the thickness of the remaining wear material reaches 0.100 IN. (2.54mm) See Fig. D-1. The M66 lining has a visible wear notch located on the end of the lining that will tell the user when the pad is at the minimum material condition.

Figure D-1

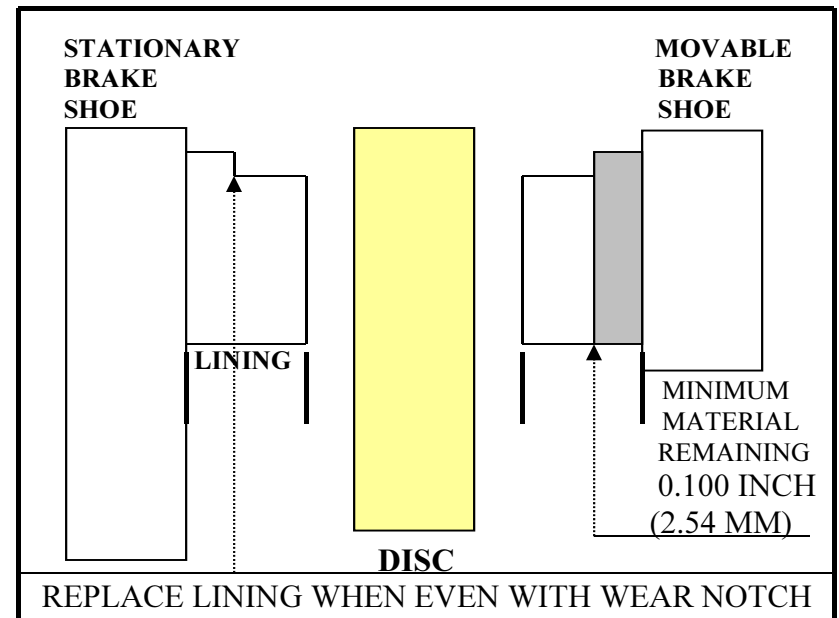

### SwiftLine Pad Replacement Program for the MHE6B

The **SwiftLine Pad Replacement program** is designed to:

- Simplify pad replacement on MATCO mfg brakes.
- Eliminate the need to rivet linings, saving maint. & tooling.
- Provide a 20% discount on reline kits, saving you money.

For more information on SwiftLine call 801-335-0582

## E. BRAKE DISC INSPECTION

The MATCO brake disc will give years of trouble free service under normal field conditions. Conditions such as unimproved fields, standing water, industrial pollution, or frequent use of the aircraft may require more frequent inspection of the brake system and disc in order to prolong the life of the brake linings.

The disc should be checked for wear (**Fig. I-1, Dim. "A"**) and for any grooves, deep scratches, excessive pitting or coning of the brake disc. Although coning is rarely a problem with the MATCO disc, if it should occur, coning beyond 0.015 inch (0.381mm) in either direction is cause for replacement.

Isolated grooves up to .030 inch (0.76mm) deep should not be cause for replacement. Any grooving of the disk however, will reduce the service life of the linings.

The MHE6B disc is plated for rust prevention. Within a few landings, the plating will wear off where the linings rub against the disc. The remaining portion of the disc will remain plated and corrosion free for an extended period of time under normal use. Chrome plated discs are available from MATCO mfg. for those demanding increased corrosion protection and wear.

Rust in varying degrees may form on the exposed portion of the disc. If a powdered rust appears on this surface, one or two braking applications during taxiing should wipe the disc clear. Rust build up beyond this point, may require removal of the disc from the wheel to properly clean both surfaces. A wire brush followed by 220-grit garnet paper should restore the braking surface adequately. Do not remove plating in areas that are not contacted by the linings.

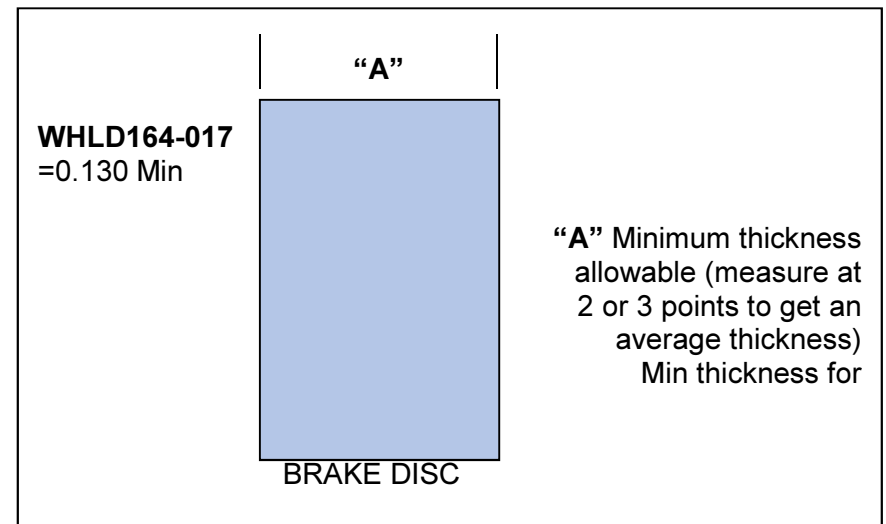

Figure E-1

## F. BRAKE LINING INSTALLATION

The following instructions offer a guide for properly removing and replacing the WHLM66-106 brake linings.

1. Remove the caliper from the wheel by removing the two MSCAN4-16A bolts that hold it on.
2. Remove old linings by drilling the crimped side of the rivet (Do not use a punch & hammer). Using a #25 drill (0.1495 diameter), drill through rivet taking care to avoid damaging the rivet hole. After drilling crimped edge off rivets, lift old lining and remaining rivet pieces from the brake shoe.
3. Inspect the brake shoe for any bending or other damage that may have occurred during service. A shoe with more than 0.010 bend should be replaced. Inspect rivet holes to ensure that no damage has occurred during removal.
4. Using a brake relining tool (*MATCO recommends a Threaded Screw Action such as the W404 from Aircraft Tool SupplyCo.*) or pneumatic press, replace the lining using the brass rivets shown on the illustrated parts list. Be sure formed head is below plate surface (fully inside the countersink) on moveable brake shoe.

## G. MOUNTING THE TIRE & TUBE

Care should be taken to avoid pinching the tube between the wheel halves when mounting the tire and tube. To avoid this, slightly inflate tube after placing it in the tire. Tire mounting soap may also help. A thin strip of cardboard or poster paper wrapped around the wheel between the mounting half and the tube will help in preventing the tube from being pinched during assembly if it is unusually tight. Another method is to use 3 ratcheting bar clamps evenly spaced around the tire and tube to compress the tire. Compress sufficiently to allow the wheel halves to be seated against each other without contacting the tire. This method is particularly useful when installing the tubeless kit since it allows the o-ring to be inspected after it is slid into place between the half edges.

## H. TUBELESS KIT INSTALLATION

1. Inspect the rim face at the radius where the o-ring will seat, for deep scratches, nicks or imperfections. Smooth out any imperfections with a medium grit emery cloth. **(Fig. H-1)**
2. Insert valve stem into the 1/2" hole and pull through from the inside of the rim. A rubber lubricant or soap and water solution may make it easier to install.
3. Take the brake half rim (*the one without the valve stem hole*) and insert it through the tire opening that will face towards the landing gear. Push the large o-ring over the diameter of the rim inside the tire and roll it back approximately 1 inch from the mating surface of the rim or all the way to the bead seat. Insert the other rim (*with the valve stem*) in what will be the outside of the tire assembly. Bolt the rims together with the three 5/16-18x.875 socket head cap screws, washers and nuts supplied spaced in every other hole.
4. Roll the O-ring to the center of the rim assembly. This is done by pushing the tire bead down evenly on the brake half side until it reaches the mating point of the two rim halves. The o-ring will seal the joint against leaks.
5. Coat the bead mounting areas of the tire and rim with a suitable lubricant and inflate the tire to specification.

6. Install the remaining 5/16-18 nuts and washers on hub bolts and install the hub.

Figure H-1

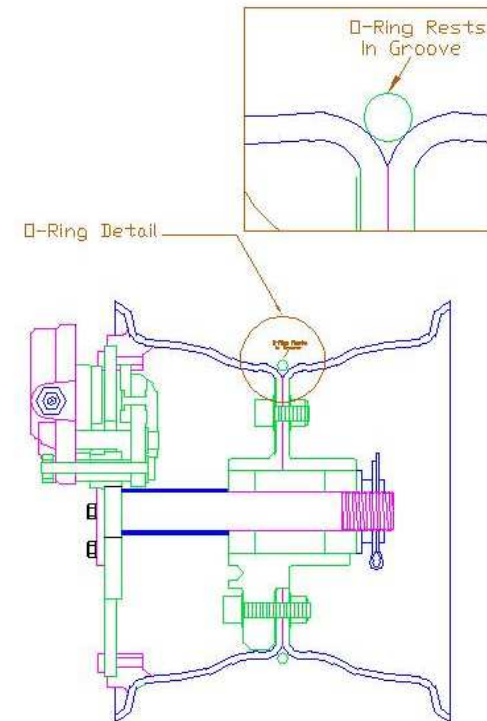

## I. MHE6B WHEEL ASSEMBLY INST.

### ASSEMBLY INSTRUCTIONS FOR SERIES MHE6B

The brake mounting plate (# 7 on assembly drawing) should be spaced from the bearing so that it aligns in the same plane and is parallel with the brake disc. (#26)

The tapered roller bearings should be packed with suitable grease. (See Section "T" for suitable lubricants.)

#### **IMPORTANT NOTE: Axle Nut Torque**

Your MATCO Mfg. wheel is equipped with tapered roller bearings that have integrated grease seals on the bearing cone to ensure the longest possible life. Torque procedures for bearings with this type of seal are different than for bearings without them. A common torquing technique for bearings without seals is to tighten the axle nut until the wheel stops spinning freely then back off to the nearest locking feature. **THIS TECHNIQUE DOES NOT WORK ON BEARINGS WITH AN INTEGRATED SEAL.** The reason for the different technique is that the grease seal produces some drag and makes the wheel feel somewhat stiff when rotated. Reducing the axle nut torque until the wheel spins freely will allow the grease seal and the bearing cone to rotate improperly with the wheel. **THE CONE MUST NOT ROTATE RELATIVE TO THE AXLE.** The higher rolling drag is completely normal for this bearing and allows for longer bearing life since the seal will keep most contaminants out.

Manufacturer specifications state that the two 1.25 tapered roller bearings used on the MHE51B will produce 8-10 inch pounds of torque (*drag*) when properly installed. A light coating of grease on the seal will help reduce the drag on initial installation. The drag will also reduce after the bearings have been installed and the seal relaxes in the bore. It is important that the axle nut torque be sufficient to keep the seal from rotating with the wheel. The following technique will ensure the longest possible bearing life.

Tighten the axle nut until all play is out of the assembly. Rotate the wheel back and forth while tightening the nut to help seat the bearings. When all play is out and the wheel rotates freely, tighten to the next slot and insert cotter pin.

The rubber seal on the tapered roller bearing should remain stationary while the wheel rotates around it. If the seal is spinning on the axle, tighten the nut further until the seal stops spinning with the wheel. (See Note Above).

All o-rings in the brake and master cylinder assembly are Buna Nitrile and are NOT compatible with automotive glycol based brake fluids.

#### **IMPORTANT NOTE: Use only red aircraft fluid Mil-H-5606 or other suitable petroleum or silicon-based fluids.**

The ideal mounting position for the brake caliper is on the trailing side of the wheel with the inlet and bleeder valve in a vertical axis. However, the caliper may be mounted at any location as long as air can be properly bled from the system.

When using MATCO bolt on axles, they can be shimmed for toe-in or toe-out conditions, and spaced out from the wheel if necessary for the brake disk attachment screws to clear the landing gear leg. MATCO manufactures aluminum axles in black anodized 6061-T6 aluminum.

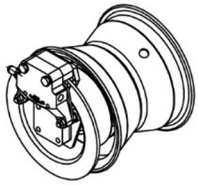

**ENTIRE ASSEMBLY:**  
 Wheel and Brake shown here  
 Wheel not shown below for  
 clarity. Hydraulics are connected  
 and system bled free of air.  
**THERE IS NO NEED TO BREACH  
 THE HYDRAULIC SYSTEM** during  
 Reline process

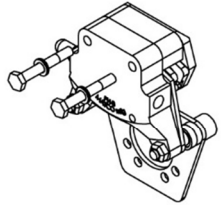

**STEP 1:**  
 Remove both (AN4) bolts and set  
 aside. The caliper is no longer  
 trapping the brake disc.

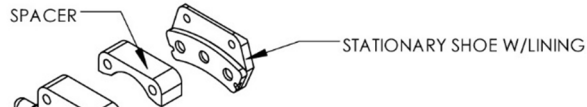

**STEP 2:**  
 Remove stationary shoe w/lining and  
 gold spacer, set aside.

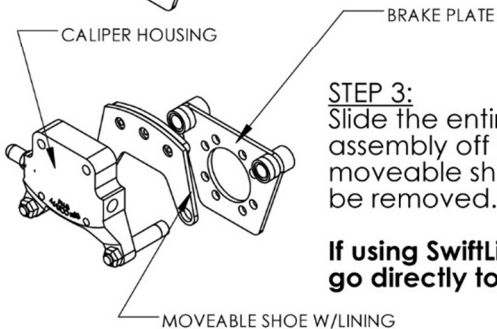

**STEP 3:**  
 Slide the entire caliper housing  
 assembly off the brake plate. The  
 moveable shoe w/lining can now  
 be removed.

**If using SwiftLine Reline Program,  
 go directly to Step 7 and go flying!**

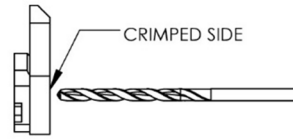

**STEP 4:**  
 Remove spent linings by drilling the  
 crimped side of the rivet (or rivet  
 removal tool). Using a #25 drill  
 (0.1495 dia), drill through the rivet,  
 taking care to avoid damaging  
 the rivet hole.

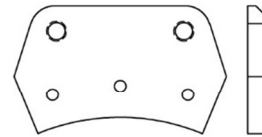

**STEP 5:**  
 After all rivets and linings have  
 been removed, inspect the brake  
 shoe for any bending\* or other  
 damage which may have occurred  
 during service, and the rivet holes  
 for any damage from removal.

\*A shoe with more than a 0.010"  
 bend should be replaced

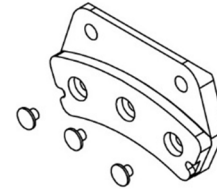

**STEP 6:**  
 Using a brake relining tool\* or  
 pneumatic press, replace the linings  
 using the brass rivets shown on the  
 illustrated parts list. Be sure formed  
 head is below plate surface (fully  
 inside the countersink) on moveable  
 brake shoe.

\*MATCO recommends a  
 threaded screw action such  
 as the W404 from Aircraft Tool  
 Supply Co

**STEP 7:**  
 Reassemble by completing steps 3  
 through 1 ( reverse order from  
 disassembly)  
 Set bolt torque as specified  
 (100 in-lb if using NL1/4 Nordlock  
 washer)  
 Verify caliper floats freely in brake  
 plate

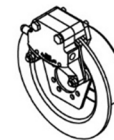



## J. WHEEL ASSY. TORQUE VALUES

DWG #	PART #	TORQUE VALUE (Inch Lbs)
1	MSCAN4-16A	100 IN Lbs
14	MSC.25-20X1.75SHCS	100 IN Lbs
16	MSC.25-20CRLOCK	80 IN Lbs
20	MSC.31-18X.875SHCS	100 IN Lbs
22	MSC.31-18X1.25SHCS	100 IN Lbs
29	MSC.31-18NYLOCK	100 IN Lbs
33	MSC.25-20X.75BHCS	100 IN Lbs

## K. CALIPER ALIGNMENT

The brake caliper must be positioned properly when assembled on the axle. When using MATCO mfg. axle WHLA3A OR WHLA3C, the caliper alignment is assured due to the bearing stops which are machined into the axle. The MHE51 wheel can also be mounted on a straight 1.25-inch axle. When using a straight axle, the required caliper spacing is shown in **(Fig. K-1)** on the next page.

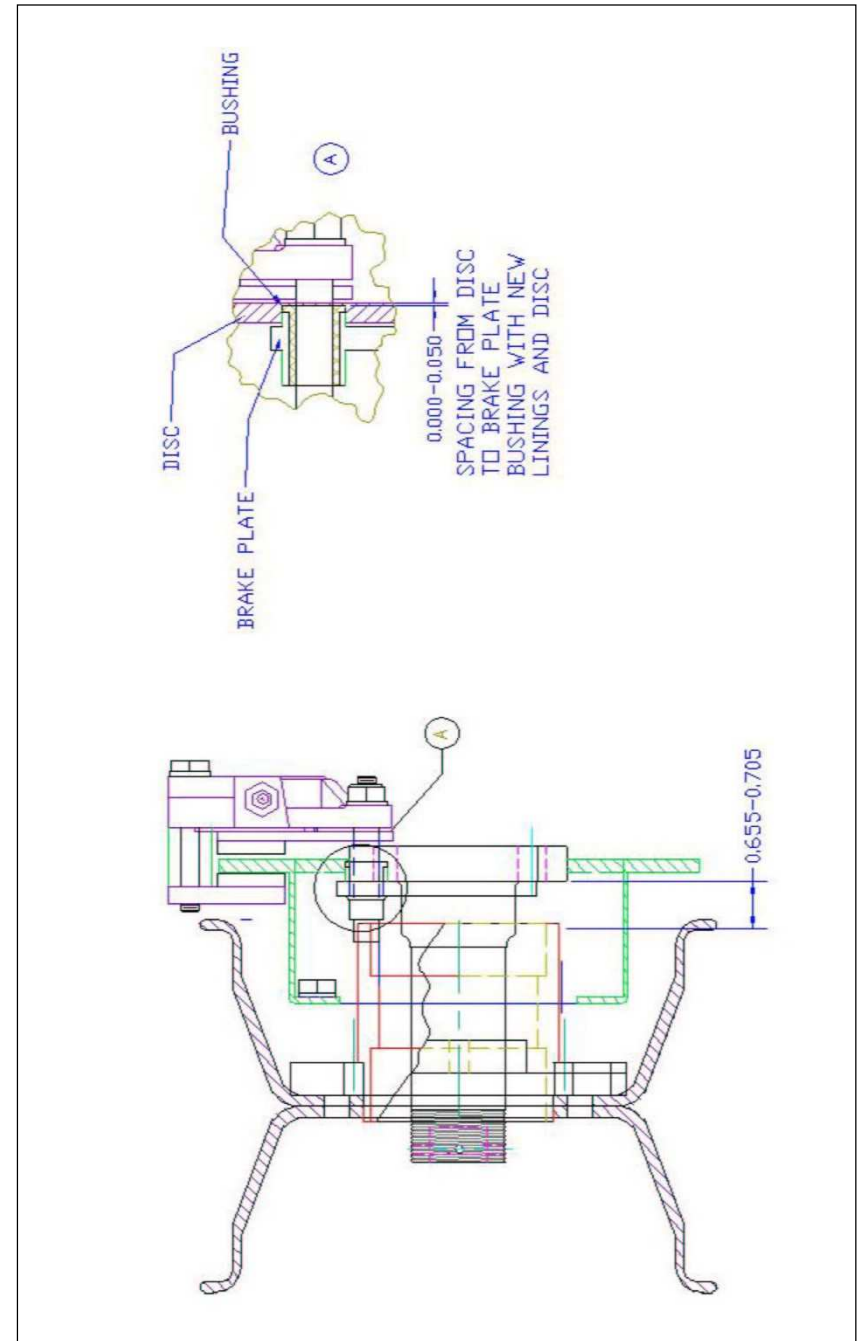

Figure K-1

## L. BLEEDING THE BRAKE SYSTEM

1. Open the brake bleeder valve slightly (# 18 on the assembly drawing) to facilitate bleeding of air from the system.
2. Attach a tube from the nozzle of a squirt can or brake bleeder unit of brake fluid, to the top of the brake bleeder valve. Pump the handle until oil flows bubble free from service hose before attaching.
3. Make sure that the master cylinder shaft is fully extended to open up the internal bypass valve.
4. Inject brake fluid (Mil-H-5606) or equivalent, into the puck housing and continue injecting until the fluid travels through the system in to the master cylinder.
5. Air in the system will be pushed up and out in to the master cylinder ONLY IF the master cylinder or remote reservoir is at the highest point in the system, and there are no loops in the brake lines.
6. Fluid should be pushed through the system until it reaches approximately  $\frac{1}{4}$  inch from the top of the master cylinder or remote reservoir
7. Close the brake bleeder valve, and remove the service hose.
8. GENTLY stroke each cylinder. If the brake system is free of air, the brake pedal should feel firm and not spongy. If not, repeat steps 1 through 7 until system is free of trapped air.
9. Fluid leakage from the top of the MCMC-5 master cylinder during operation indicates too high a fluid level.
10. Ensure that all drilled bolts are properly safety wired.

### IMPORTANT NOTE

The MCMC-5 is NOT approved for inverted flight.

Figure L-1

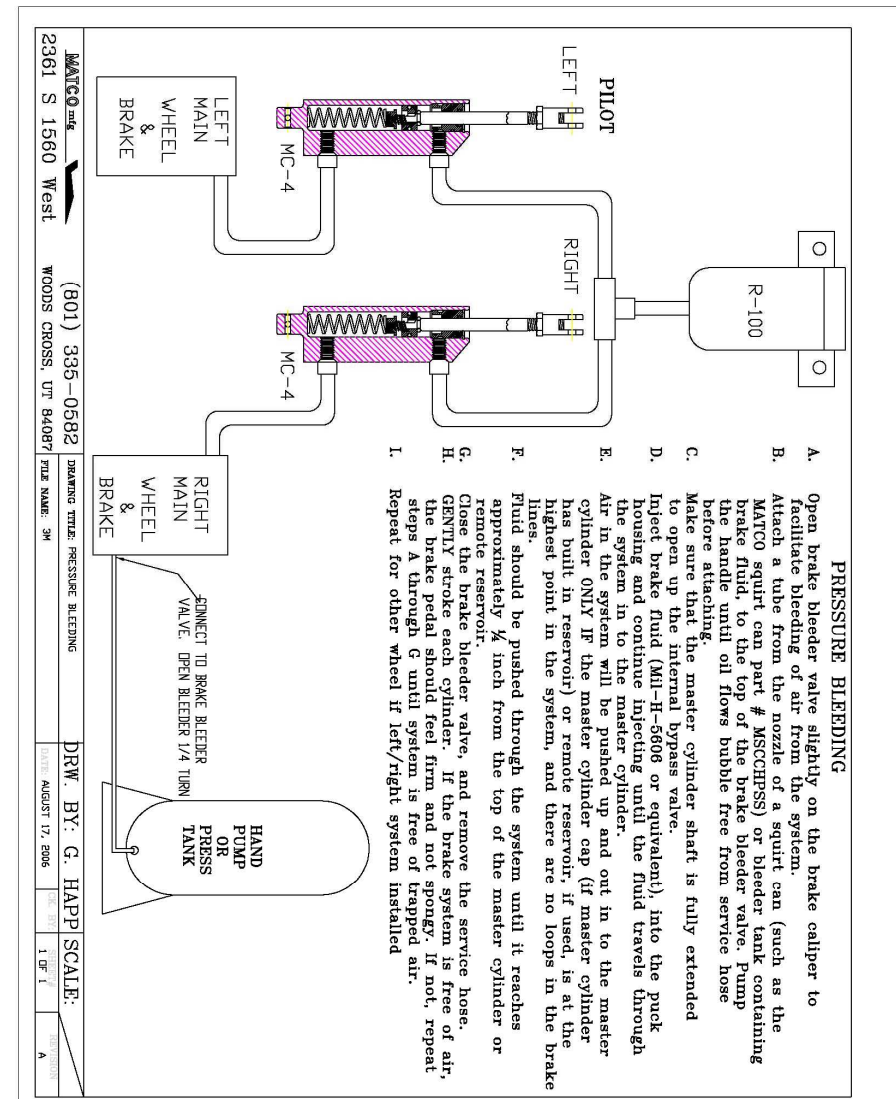

## M. CONDITIONING PROCEDURES

**NOTE:** It is important to condition the new linings after installation to obtain maximum service life and performance. The procedures below show when and how this should be done.

1. After the linings have been installed, apply brake pressure during high throttle static run-up. Note RPM at creep if any occurs.
2. Perform 2-3 high-speed taxi snubs to generate 300-400 degrees at brake pads and rotor by accelerating the aircraft to 30-40 mph. Remove power and apply firm braking pressure until slowed to 5 mph and release pressure. Do not bring aircraft to a complete stop during the taxi snubs. After accomplishing the snubs, do not drag the brakes. Allow the aircraft to roll as brake free as practicable until back to the tie down area. Avoid stopping the aircraft completely as much as practicable and park with brake pressure off.
3. Repeat step one and note RPM at creep if any occurs. There should be a noticeable increase in holding torque.
4. If properly conditioned, the pads will have a uniform shiny appearance (*glaze*) on the surface. Repeat steps 1-3 if necessary to produce glaze.

**NOTE:** Forward movement of the aircraft during static run-up could be caused by the wheels skidding and not brake malfunction. Use caution when braking heavy on aircraft with a tailwheel as it could cause the tail to lift from the ground.

Conditioning removes high spots, and creates a layer of glazed material at the lining surface. Normal braking will produce enough heat to maintain glazing during the life of the lining. Glazing can be worn off during light use such as taxiing.

Figure L-2

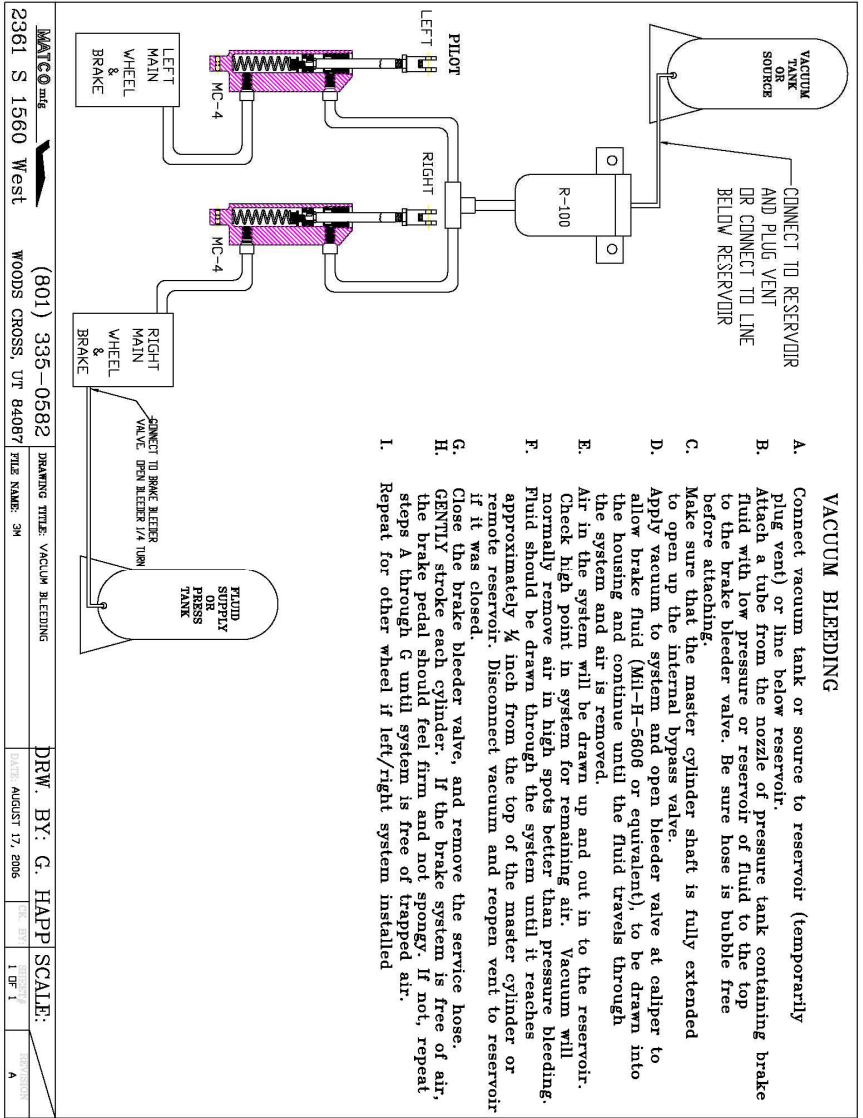

## N. MAXIMIZING BRAKE OUTPUT

### GETTING YOUR PEDAL GEOMETRY RIGHT

#### BRAKE SPECIFICATIONS

##### ENERGY RATING

All MATCO mfg. brakes have two specified ratings. The first is the energy rating which specifies the energy capacity of the brake. This value is used in selecting a brake that will be able to absorb the kinetic energy of the aircraft under the designers specified maximum energy condition (*generally maximum aircraft weight at a velocity above stall speed*). The energy rating is determined by the disc weight. Exceeding the energy capacity of a braking system leads to excessive disc temperatures. This can cause low friction coefficients and reduce brake torque and aircraft deceleration. Permanent damage to the disc can result in the form of warping or loss of corrosion protection.

##### BRAKE TORQUE

The second rating is for brake torque. The rated torque value is used to determine the deceleration and static torque for engine run-up that will be provided by the brake. A braking system using the same disc can have one energy rating and several torque ratings. This is possible by using different caliper configurations on the same disc. For example a braking system using a single caliper on a disc with a 189K ft-lb rating may have a torque rating of 1980 in-lb. The same braking system using two calipers would have the same energy rating of 189K ft-lb but would have a torque rating of 3960 in-lb. MATCO mfg. offers its customers a wide range of caliper configurations and disc sizes to allow for meeting both energy and torque requirements for their aircraft.

##### GETTING THE RATED TORQUE

The rated torque value assumes a nominally conditioned brake pad (*see pad conditioning procedures section 'R'*), rated pressure applied to the brake, free floating calipers, and pad contact on both sides of the disc. Brake pad conditioning allows a glaze to form on the pads and provides the highest friction coefficient and drag force. MATCO mfg. brake torque ratings are based on 450 psi applied pressure. Pressures below this value will generate proportionally lower torque. Pressures above this value will provide higher torque although pressures above 600 psi generally cause caliper deflections that reduce the torque increase. The torque rating assumes that all caliper force is used to squeeze the brake pads against the disc. If the caliper does not float freely, it is possible that only one side of the disc surface may be contacted resulting in 50% loss of torque.

##### GET THE PRESSURE RIGHT

Assuming the calipers are properly mounted so that the pads make contact on both sides of the disc (*both new and worn*) and are maintained so that the calipers float freely, the most common reason for under performance of the brakes is low pressure. MATCO mfg. brakes need 450 psi to achieve their rated torque. Additional calipers can be added to get higher torque at a lower pressure but it is often more weight efficient to modify the hydraulic system pedal geometry to generate high pressures. Systems using hand or foot operated master cylinders require a minimum of 2.5 to 1 mechanical advantage when using master cylinder, MC, like the MC-4 or MC-5 which have .625 inch diameter pistons. (*Systems using MC-4 or MC-5 with intensifiers have .500-inch pistons and require a 1.6 to 1 mechanical advantage*). Mechanical advantage, MA, is the ratio of the force applied to the master cylinder shaft divided by the force applied by the hand or foot. **Dia. 1** shows two examples of pedal geometry.

The first has an MA of 1 to 1 since the distance from the applied load to the pivot point is the same as the distance to the MC and is undesirable. The second shows a more favorable configuration that will easily provide the required pressure to the brakes with moderate toe force.

It is often necessary to keep the foot pedal shorter than that shown in **Dia. 1**. An alternate geometry is shown in **Dia. 2**. This design would utilize a fork arrangement on the MC connection to allow clearance of the MC body and then a short linkage to the MC connect point. A design common to many aircraft uses linkage as shown in **Dia. 3**. This design also allows for a shorter brake pedal but has a major disadvantage. This linkage can be configured to have a proper MA in the start position (with the master cylinder fully extended). The MA varies with rotation however, as shown in **Fig. 2 of Dia. 3**, a 15 degree rotation of the linkage reduces the MA at the start position from 1.5 to 1 down to only 1.12 to 1. In actual operation, this has the effect of causing a nearly constant brake torque even though increasing force is applied. For example, if the geometry is set for an initial MA 2.5 to 1. In the start position and the pilot applies pedal force, the MC will begin to stroke as pressure builds. As the rotation occurs, the MA decreases. If there is any air in the brake lines or if there are long brake line runs, hydraulic system expansion will occur as pressure increases requiring more MC stroke. If the pilot applies more pedal force, more MC stroke occurs, and the MA decreases further. Even though the pilot has now increased his pedal force, the force applied to the MC will be only marginally increased because more rotation will result and cause a further decrease in MA. A geometry like that in **Dia. 2** will provide the same reduced pedal height and is not prone to the effect of rotation since the MC is essentially connected to the brake pedal pivot. **Dia. 4** illustrates the benefit of pivot connect geometry during rotation. The MA remains virtually unchanged for expected rotation angles and results in a linear pressure increase with applied pedal force.

## HEEL BRAKES

A common means of providing pilots with differential braking ability without resorting to a more complicated geometry of toe brakes is to use heel brakes. The same design requirements exist for the MA of a system using heel brakes as for toe brakes. It is not uncommon to see MC's configured to allow the pilot to apply heel force directly to the MC by means of a pad or button connected on the end of the shaft. This configuration is shown in **Fig. 1 of Dia. 5**. The MA of this system is 1 to 1 and produces very low pressure for reasonable heel force. Perhaps a larger concern however is the potential for causing damage to the MC. The MC is designed to accept loads applied along the length of the shaft. Loads applied off axis or perpendicular to the shaft cause bending moments in the MC shaft that it is not designed for. Damage to the MC end gland, or bending of the MC shaft may result if the off axis brakes is shown in **Fig. 2 of Dia. 5**. This system uses a short linkage connected to the MC that provides the 2.5 to 1 MA while insuring that loads will be applied along the length of the MC and prevent any damage during actuation.

## CONCLUSION

Like any system on an aircraft, the hydraulic system has many engineering options for providing the necessary requirements. The systems common on light aircraft must be engineered to provide adequate pressure to the brakes to achieve the rated torque. MATCO mfg. brakes require 450 psi to achieve the rated torque. The pedal geometry whether hand, toe, or heel operated, requires a mechanical advantage of at least 2.5 to 1. This allows the pilot to easily generate the required 450-psi with moderate applied force. Pivot connected geometry provides the best means of accomplishing this requirement without the problem of rotational effect that reduces mechanical advantage.

**PEDAL GEOMETRY / POOR & MINIMUM**  
**Diagram 1, Figures 1 & 2**

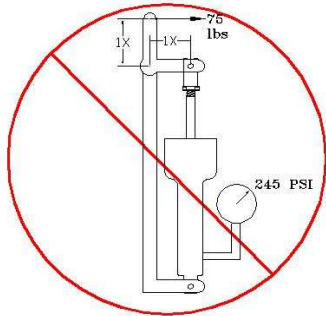

FIG 1  
 Poor  
 Geometry

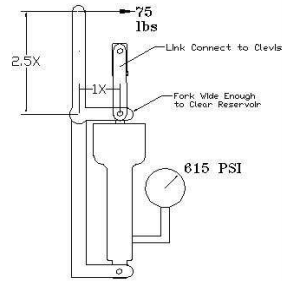

FIG 2  
 Minimum  
 Geometry

**PEDAL GEOMETRY / POOR & MINIMUM**  
**Diagram 2, Figures 1 & 2**

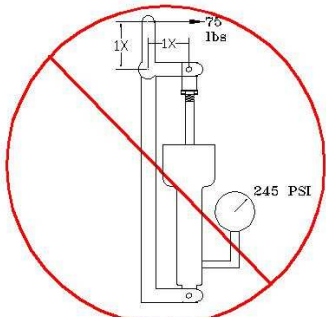

FIG 1  
 Poor  
 Geometry

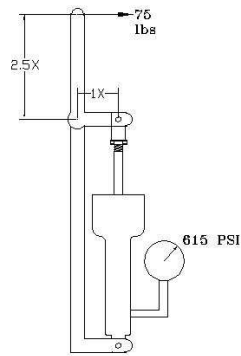

FIG 2  
 Minimum  
 Geometry

**PEDAL GEOMETRY / MECHANICAL ADVANTAGE**  
**Diagram 3, Figures 1 & 2**

MC CONNECTED ABOVE PIVOT  
 ROTATION OF 15°  
 MECH ADV DECREASES WITH  
 ROTATION

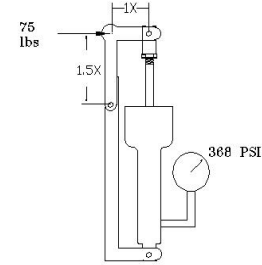

FIG 1  
 MECH ADV =  
 $1.5/1 = 1.5$  to 1

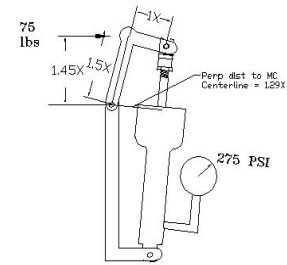

FIG 2  
 MECH ADV =  
 $1.45/1.29 = 1.12$  TO 1

**PEDAL GEOMETRY / PIVOT CONNECT**  
**Diagram 4, Figures 1 & 2**

MC CONNECTED AT PIVOT  
 ROTATION OF 15°  
 MECH ADV REMAINS APPROX  
 UNCHANGED

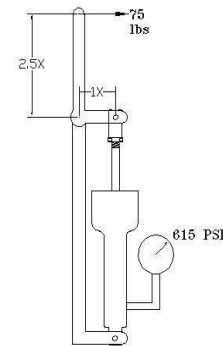

FIG 1  
 MECH ADV =  
 $2.5/1 = 2.5$  to 1

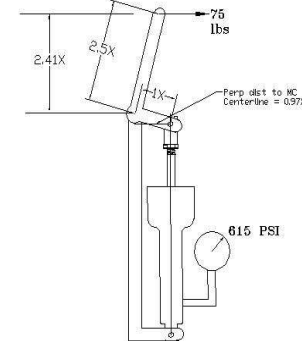
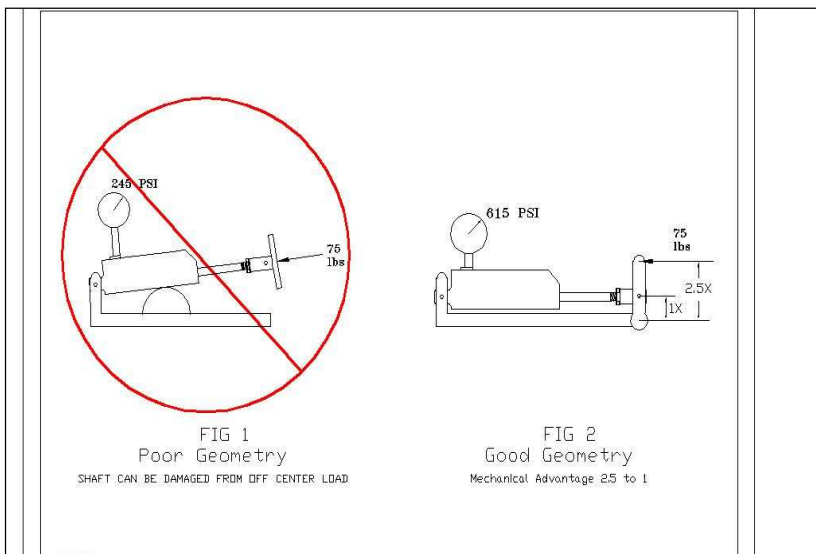

FIG 2  
 MECH ADV =  
 $2.41/0.96 = 2.5$  to 1

**PEDAL GEOMETRY / HEEL BRAKES**  
Diagram 5, Figures 1 & 2



**O. LUBRICANTS**

**ELASTOMERIC COMPOUND LUBRICANTS**

HYDRAULICS: MIL-H-5606 / MIL-H-83282  
or equivalent (Red Oils)

**PETROLEUM LUBRICANTS**

WHEEL BEARINGS: MIL-G-81322  
MOBIL 28  
AEROSHELL 22  
MOBIL SHC-100  
or equivalent lubricants

AMPHIBIOUS: HCF Grease P/N 605  
BG Products, Wichita, KS.

**THREAD SEALANT**

TAPERED PIPE THREADS: Loctite 567, or equivalent



## P. TECHNICAL ASSISTANCE

For technical information, product matching, and helpful hints, visit our website at:

[www.matcomfg.com](http://www.matcomfg.com)

E-mail our Technical Service Manager for specific information at:

[tech@matcomfg.com](mailto:tech@matcomfg.com)

### TECHNICAL ASSISTANCE

To speak with someone in person about specific products or to find answers to technical questions, please contact us at:

**TECHNICAL HOTLINE**  
**801-335-0582**

### TECHNICAL SUPPORT DISCLAIMER:

While we at MATCO mfg. strive to ensure that the advice/information provided through our support is correct, MATCO mfg. does not accept any responsibility for errors or omissions. Any advice or information that MATCO mfg. gives you, via any form of communication is not a guarantee that it will correct your problem. It is only offered as assistance to you.

MATCO mfg. will not be held responsible for any loss or damage as a result of our advice or information supplied.

## NORD-LOCK Washers

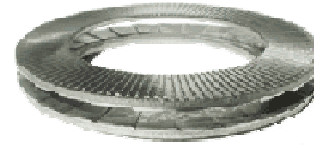

NORD-LOCK is a pair of washers with a wedge-locking action meeting DIN 25201 which is a unique method using tension instead of friction. The rise of the cams between the NORD-LOCK washers is greater than the pitch of the bolt. In addition, there are radial teeth on the opposite side. The washers are installed in pairs, cam face to cam face.

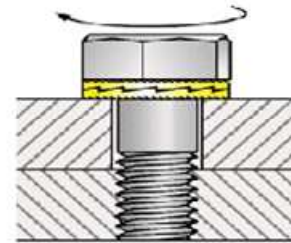

When the bolt and/or nut is tightened the teeth grip and seat the mating surfaces. The NORD-LOCK washer is locked in place, allowing movement only across the face of the cams. Any attempt from the bolt/nut to rotate loose is blocked by the wedge effect of the cams.

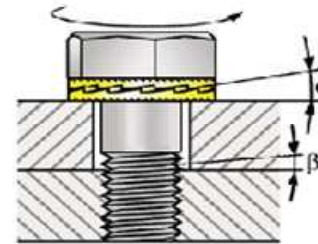

Here you see what happens when a bolt is untightened with a wrench. The pair of washers expand more than the corresponding pitch of the thread allows the bolt/nut to rise.

NORD-LOCK washers positively lock the fastener in a joint which is subjected to any kind of vibration or dynamic loads.

REPLACE the NORD-LOCK washers if the cam surface is worn and corners are rounded or if the pair does not seat cleanly against each other

### NORDLOCK TORQUE VALUES

MSCNL5	#10	80 in-lb	MSCNL1/4	1/4" Shoulder	100 in-lb
MSCNLX6	1/4" All-Thread	100 in-lb	MSCNL8	5/16"	120 in-lb

**Verify bolt bottoms against surface before installing NordLock**



**QUICK REFERENCE  
MY AIRCRAFT INFORMATION**

WHEEL MODEL # \_\_\_\_\_

BRAKE ASSY \_\_\_\_\_

MHE6B.75	WHLBE5-15
MHE6B1.25	WHLBE5-1
MHE6B1.25EV	WHLBE5-11
MHE6B1.25-G	WHLBE5-1
MHE6B1.25-SC	WHLBE5-2
MHE6B1.25Z	WHLBE5Z-1
MHE6J1.25	WHLBE5-5

(Pages 4-9) BRAKE LININGS     WHLM66-106    

BRAKE FLUID MIL-H-5606 or equivalent \_\_\_\_\_

(Page 4-9) BRAKE DISC     WHLD164-017    

(Page 15) MIN DISC THICKNESS     0.130    

**NOTES**

---

---

---

---

---

---

---

---

---

---

---

---