

USE Mil-H-5606 Hydraulic Fluid

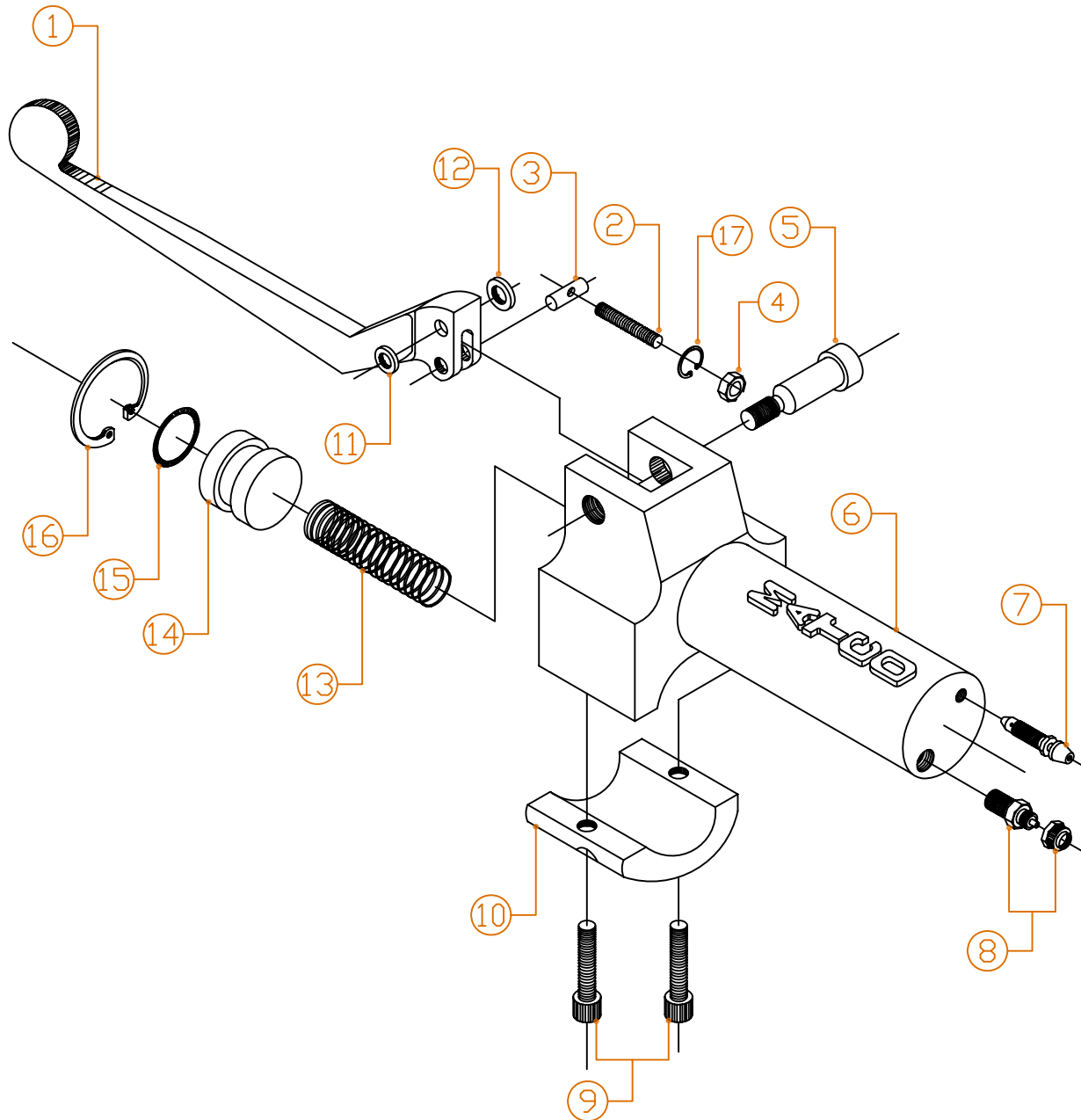

NO.	INVENTORY NO.	PART NAME	REQ'D
1	MC6-1	ACTUATOR LEVER	1
2	8-32X1.125	SOCKET SET SCREW	1
3	.25-X.550PIN	ROTATOR PIN	1
4	8-32SCREWNUT	SCREW MACHINE NUT	1
5	.25X.75SB	.25 X .75 SHOULDER BOLT	1
6	MC6H(A)	HOUSING, MC-6	1
7	F6446-007	BRAKE BLEEDER VALVE	1
8	268P	STRAIGHT FITTING	1
9	10-24X.75SHCS	SOCKET HEAD CAP SCREW	2
10	MC6-2	CLAMP	1
11	AN960-10L	WASHER	1
12	AN960-416L	WASHER	1
13	LC-042F-9	SPRING	1
14	MC6P.75	PISTON	1
15	2-113	O-RING BUNA N	1
16	3000-X75	SNAP RING	1
17	3000-X37	SNAP RING	1