

ITEM #	Part Number	Description	QTY.
1	MSC.25-20X1.25BHCS	SCREW, BUTTON HEAD	3
2	MSC6302RS	Bearing, Ball 15mm	2
3	WHLW60C15MM	WHEEL HALF, DIE CAST	2
4	MSC.25-20NYLOCK	NUT, NYLOCK	3

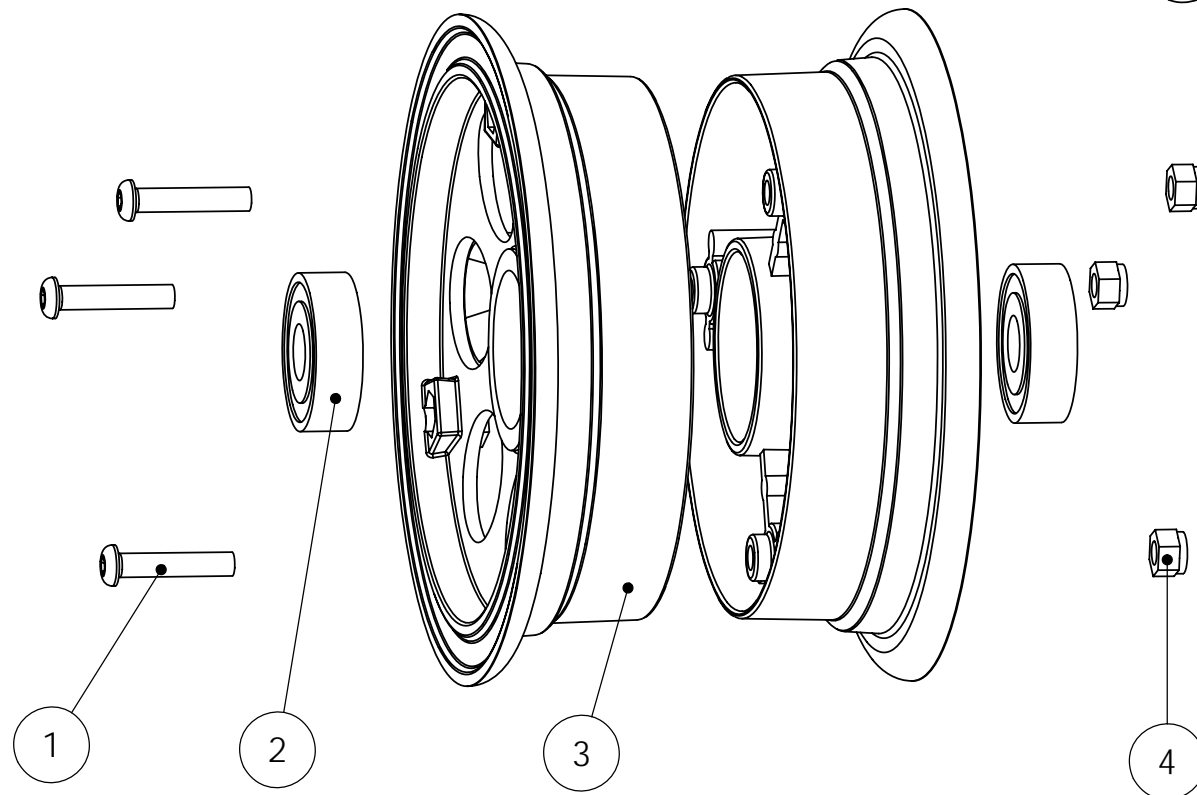

MATCO mfg

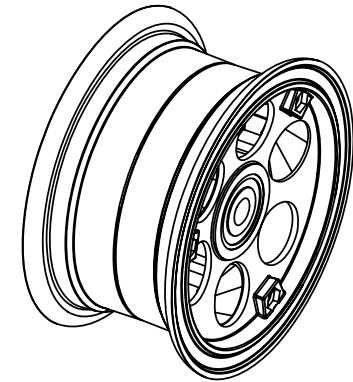

2361 S 1560 West
Woods Cross, UT 84087 USA

NOMENCLATURE
WHEEL, NOSE NW60CC15MM

PART NUMBER
WHLNW60CC15MM

SCALE
1:2

TOLERANCES
(EXCEPT AS NOTED)

MATERIAL
VARIES

DRAWING NO.
3D-NW60CC15MM

REVISION
NC

Est Wt. (lb)
3.191

DO NOT SCALE DRAWING
LINEAR .XX = + .03
.XXX = + .01
ANGULAR ± 1/2
CONCENTRIC ± .01

DRAWN BY
George R. Happ

FINISH

DATE
4/23/2008

CHECKED BY

SHEET 1 OF 1
SHEET SIZE A